



# Outline

- High stiffness, low deflection issues
  - Tie-ballast load effects
  - Rail-Tie load effects
- Low Stiffness, high deflection issues
  - Rail – Tie load effects
  - Influence on tie vibration and failure
- Tie Support Characterization and Specification
- Summary

---

# Case Study of Concrete Tie Base Wear with Implications for Tie Performance

---

**Ted Sussmann**  
**International Cross Tie Symposium**  
**University of Illinois Urbana Champaign**  
**June 2014**

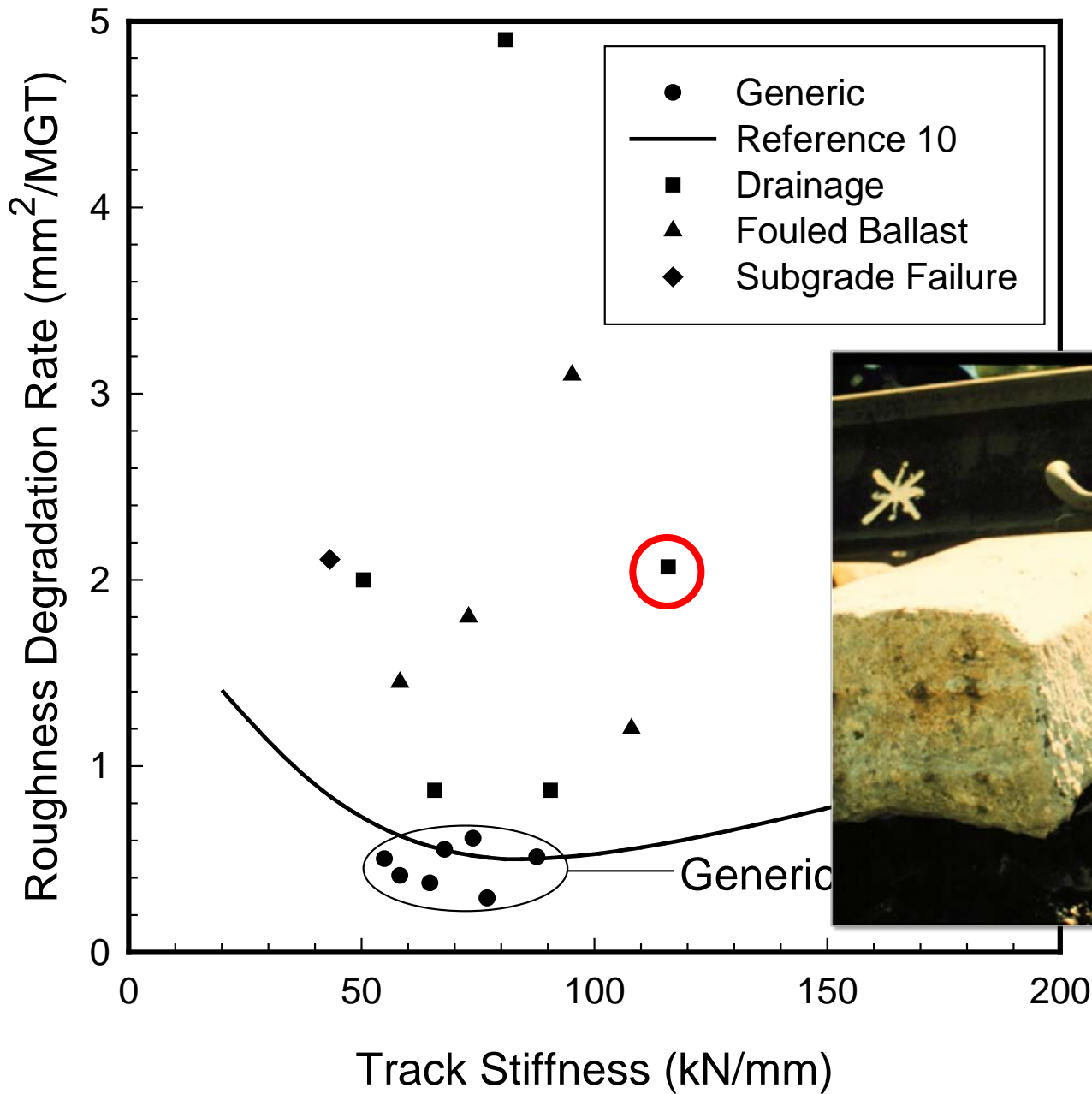

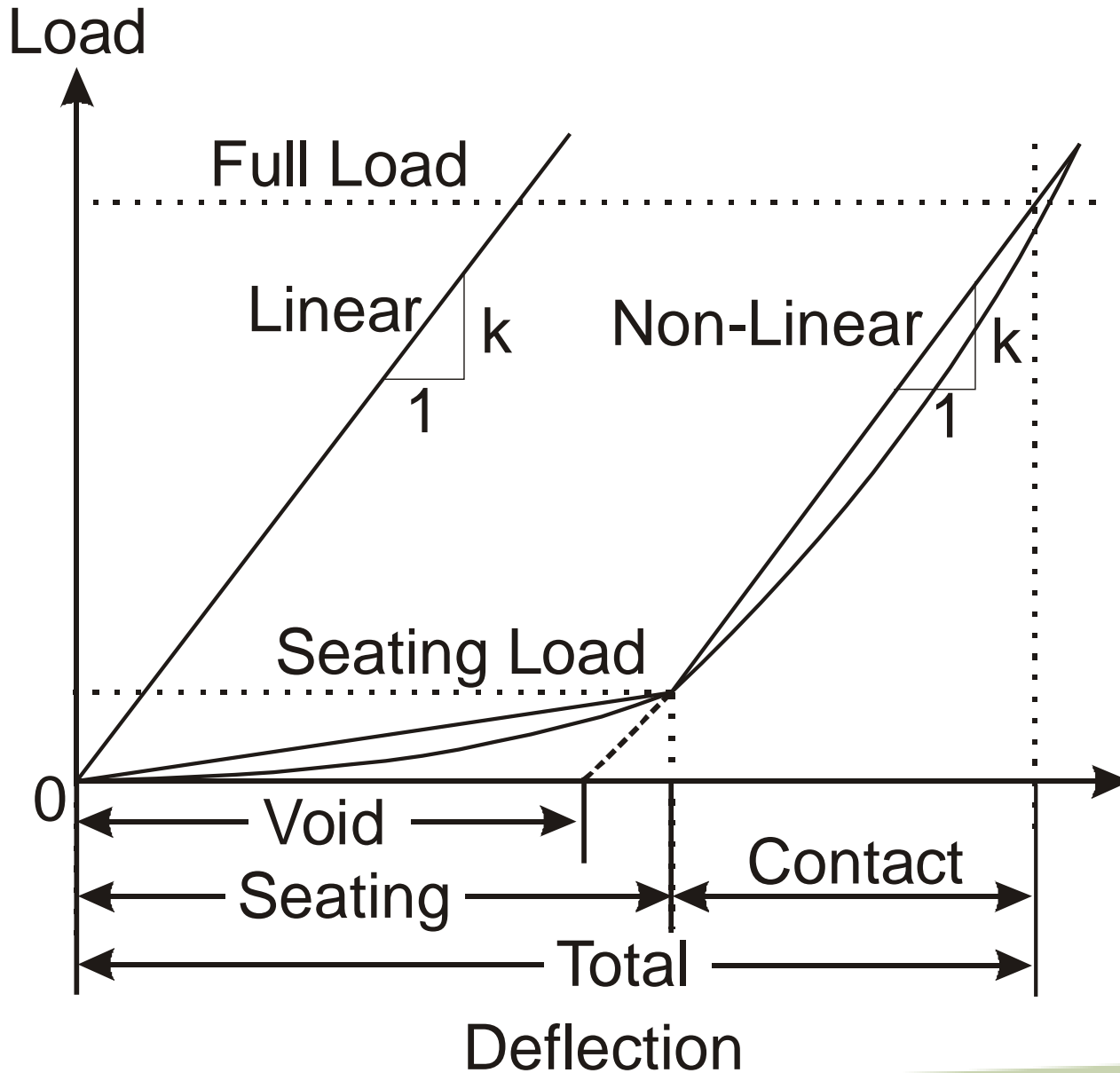

**Too soft:**

- Ballast instability
- Subgrade failure
- Joint bar overload

**Too stiff:**

- Rail corrugation
- Tie abrasion
- Ballast crushing
- Crushed railhead

**Large void:**

- Track shift/buckling
- Track geometry
- Tie failure
- Fouled ballast

# Track Deflection Variations

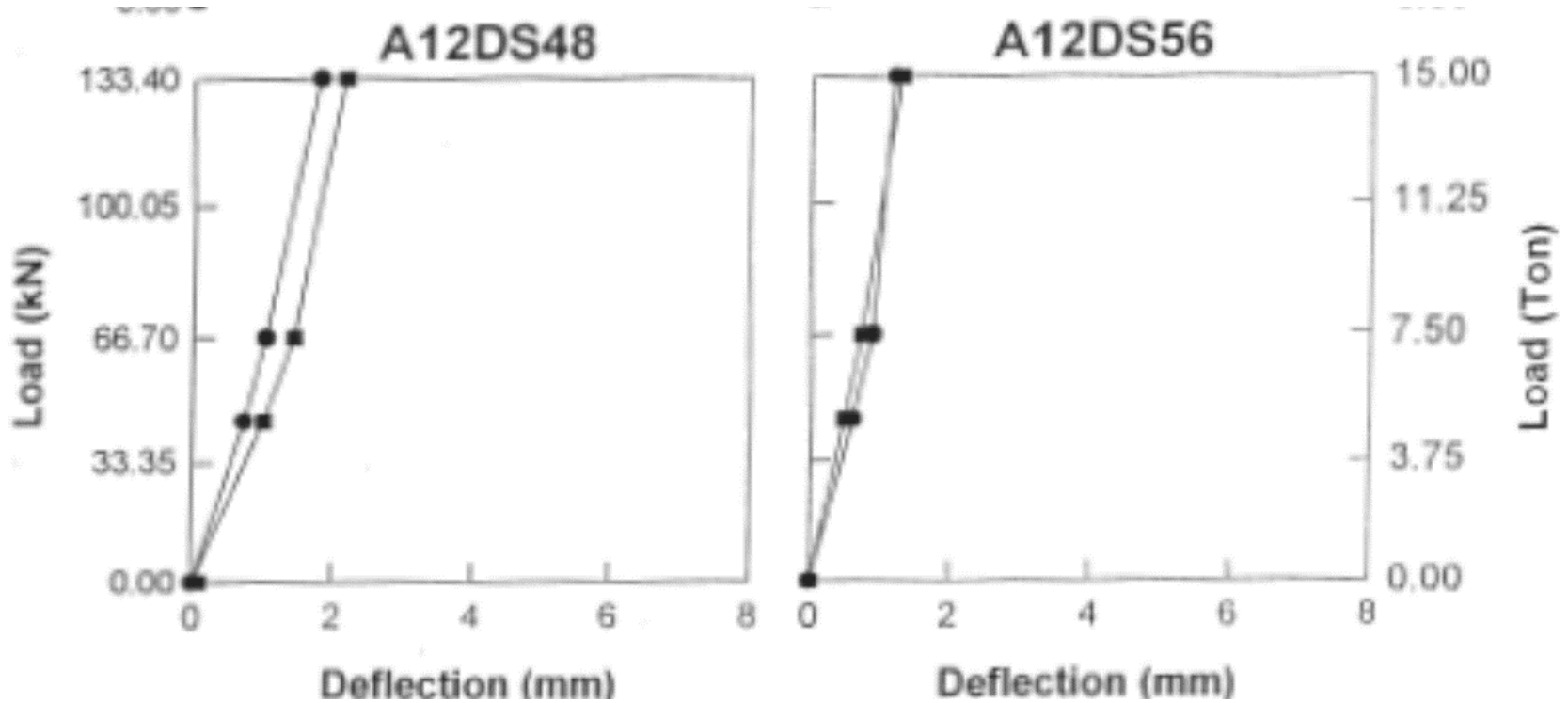

# Track Substructure Influences on Tie Support Conditions

Ted Sussmann



**Tie Symposium**  
**University of Illinois Urbana Champaign**  
**June 2016**

**Volpe** The National Transportation Systems Center  
*Advancing transportation innovation for the public good*

 U.S. Department of Transportation  
Office of the Assistant Secretary for Research and Technology  
John A. Volpe National Transportation Systems Center

# Rail Seat - Eccentrically Loaded Support

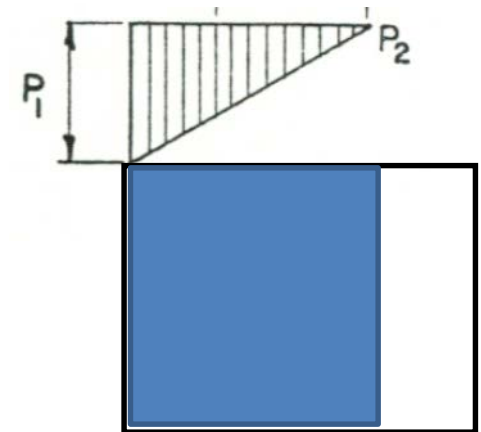
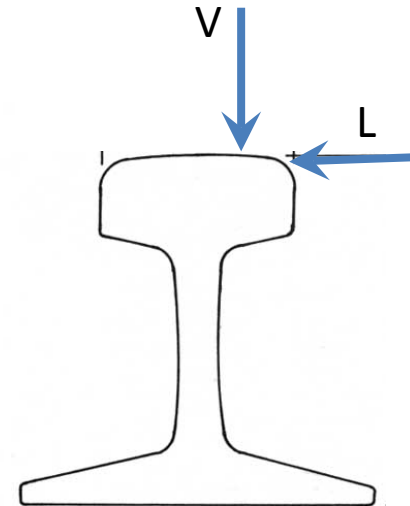
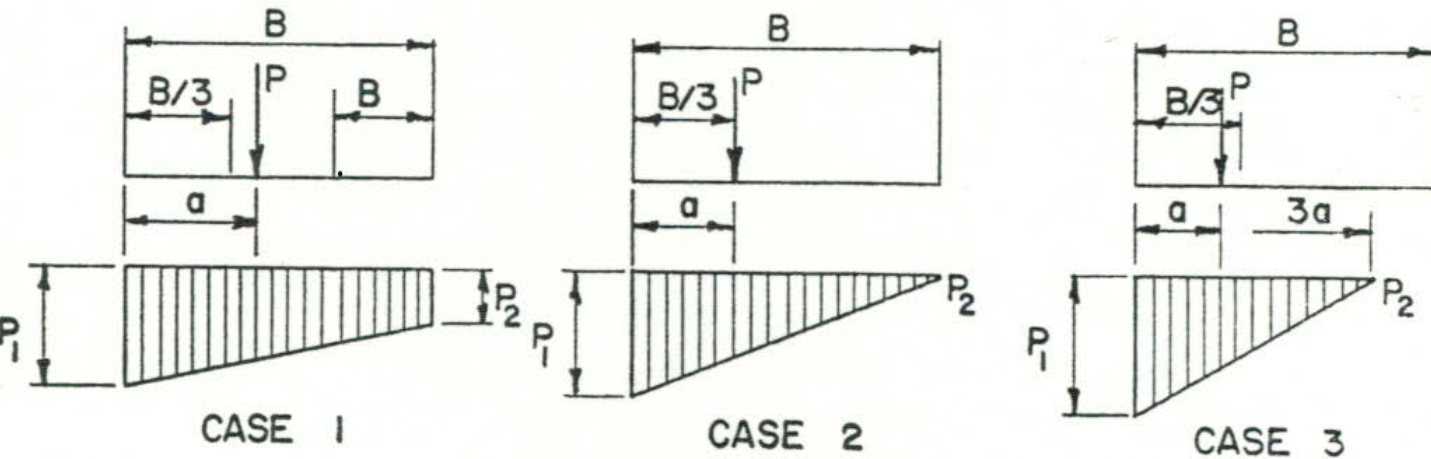

Case 1—Resultant within the middle third.

$$p_1 = (4B - 6a) P/B^2$$

$$p_2 = (6a - 2B) P/B^2$$

Case 2—Resultant at edge of middle third.

$$p_1 = (4B - 6a) P/B^2 = 2P/B$$

$$p_2 = (6a - 2B) P/B^2 = 0$$

Case 3—Resultant outside the middle third.

$$p_1 = 2P/3a$$

$$p_2 = 0$$

Source: AREA manual  
(1958)

# Rail Seat Support - UIUC at TTCI

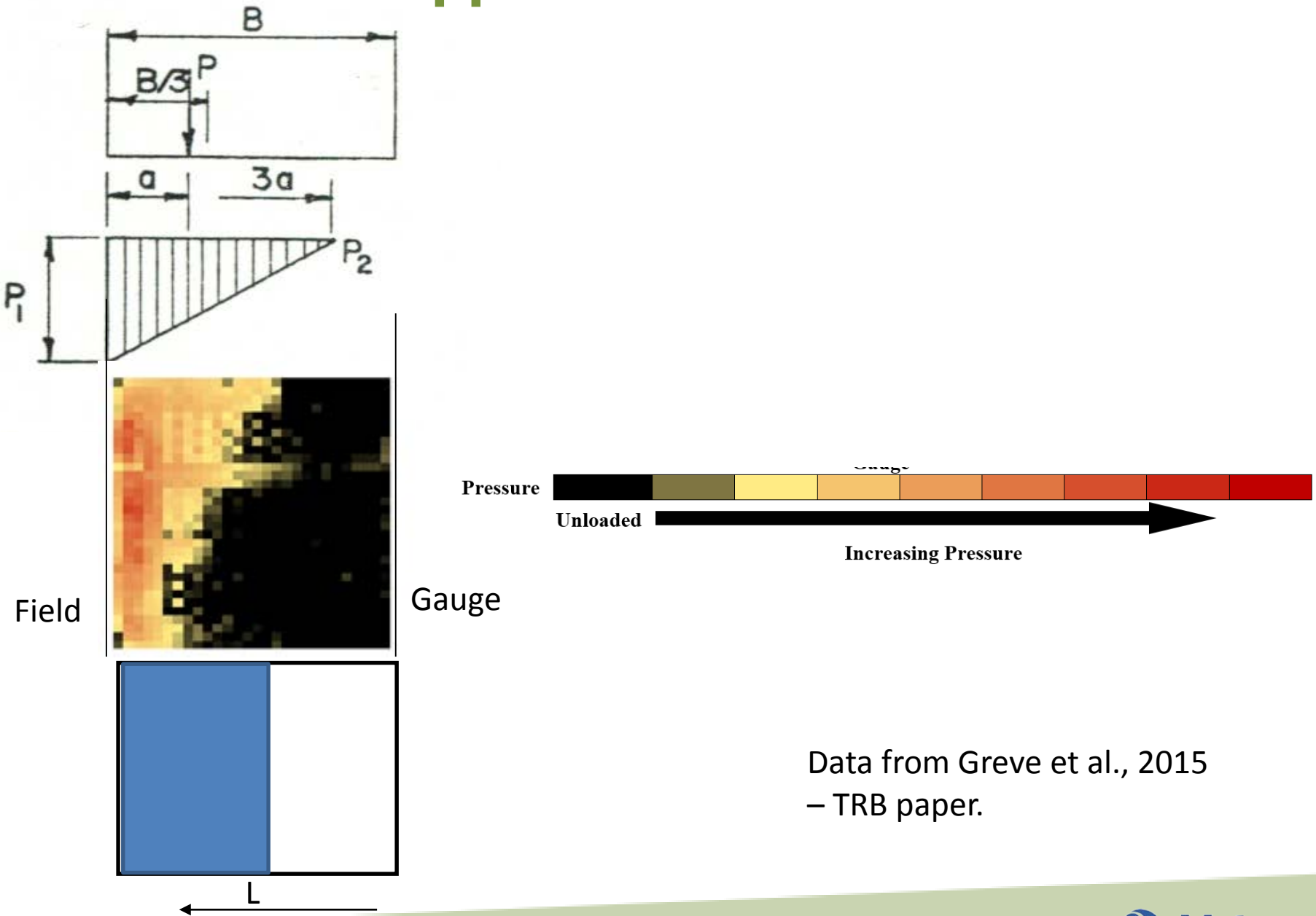

Data from Greve et al., 2015  
– TRB paper.

# Rail Support: Two Way Eccentricity

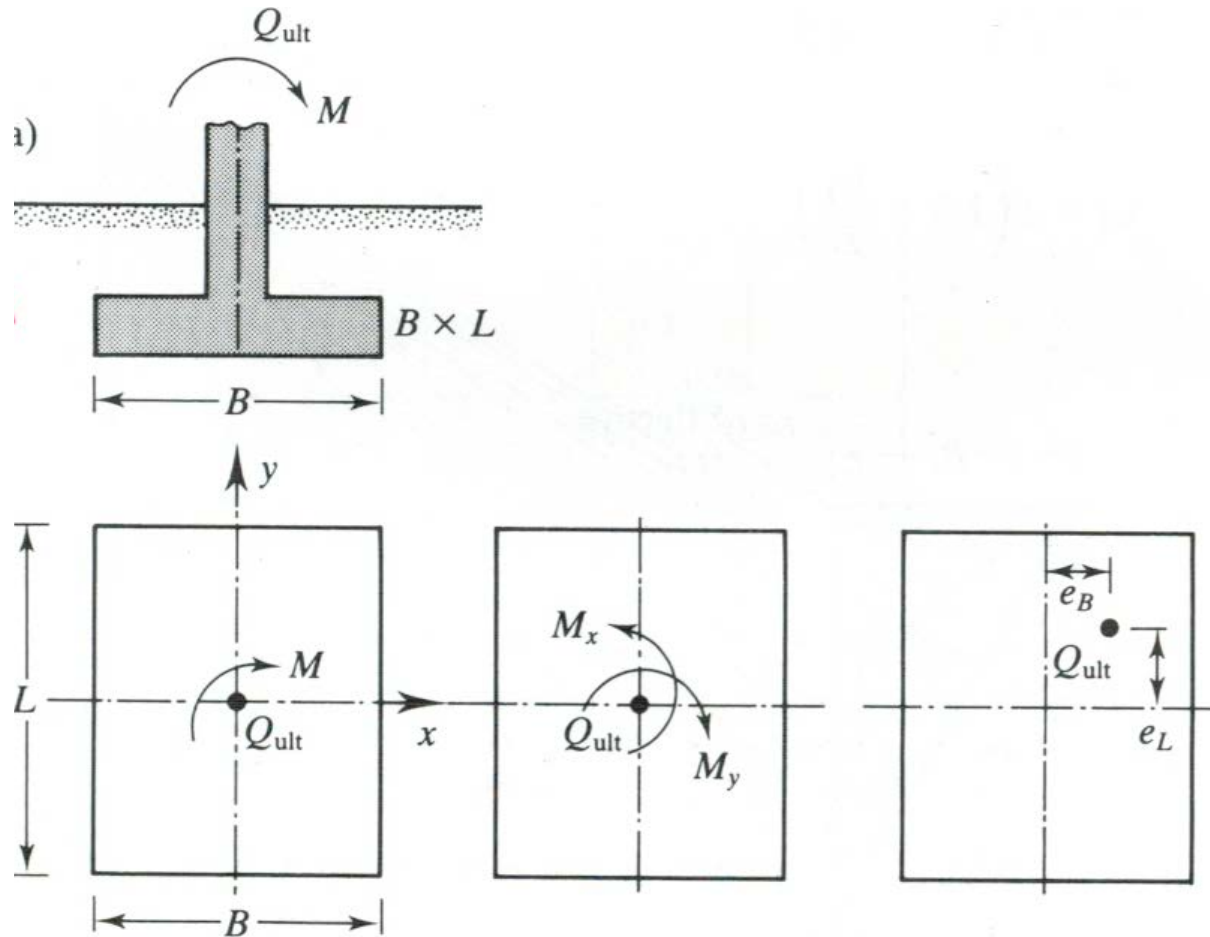

# Rail Support: Two Way Eccentricity

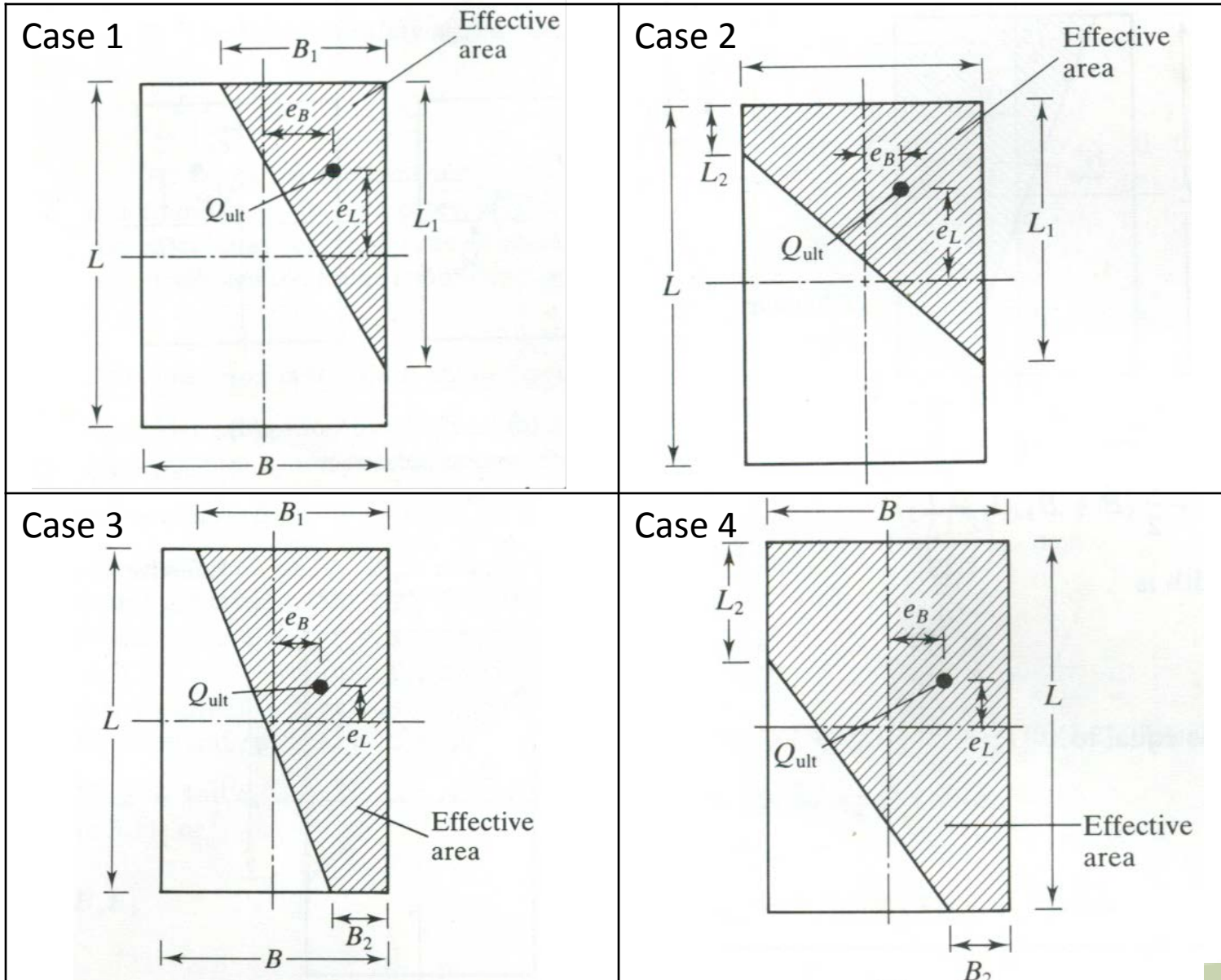

# Rail Seat Load: Effect of Missing or Unsupported Tie(s)

- ❑ Unsupported tie
  - Small increase in deflection
  - Large transfer of load to adjacent tie
- ❑ Increase rail deflection
  - 1.5-2 times static (Carr, 1999)
- ❑ Increase adjacent tie load
  - Up to 3+ times static (Kerr, 2003)
  - Depending on tie support

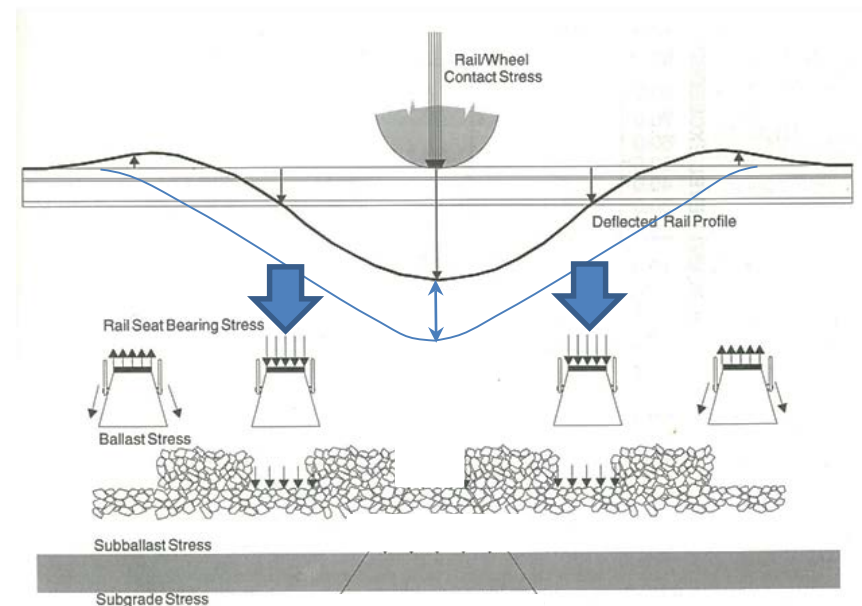

# Rail Seat Load: Tie Support Effects

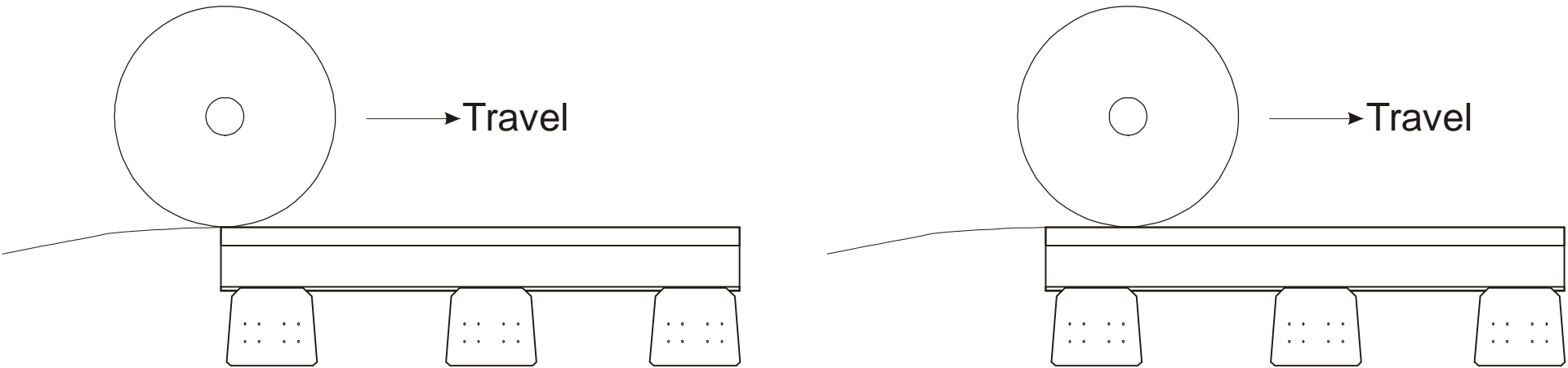

Travel

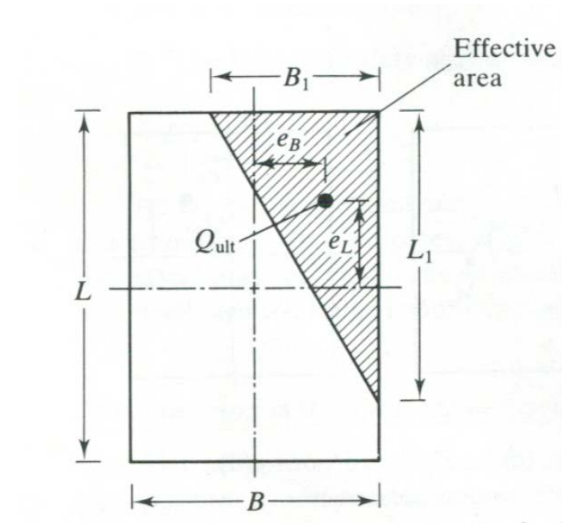
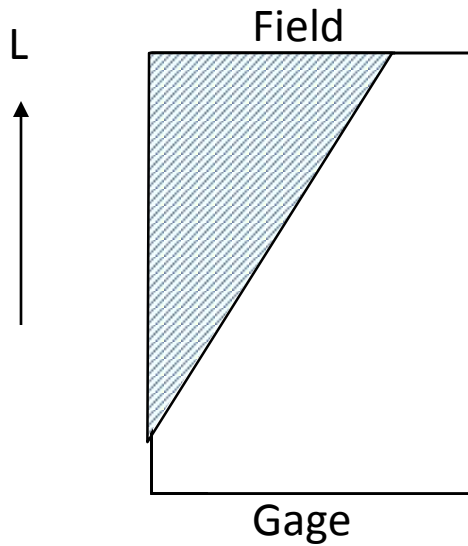
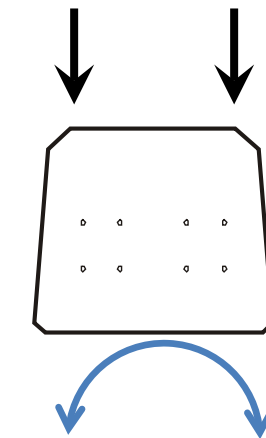

# Rail Seat Support Measurements - TTCI

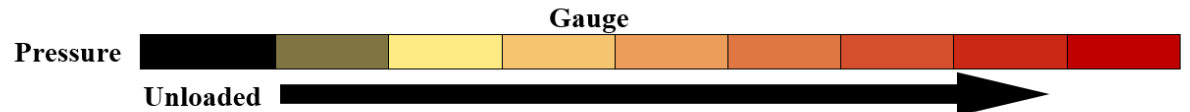
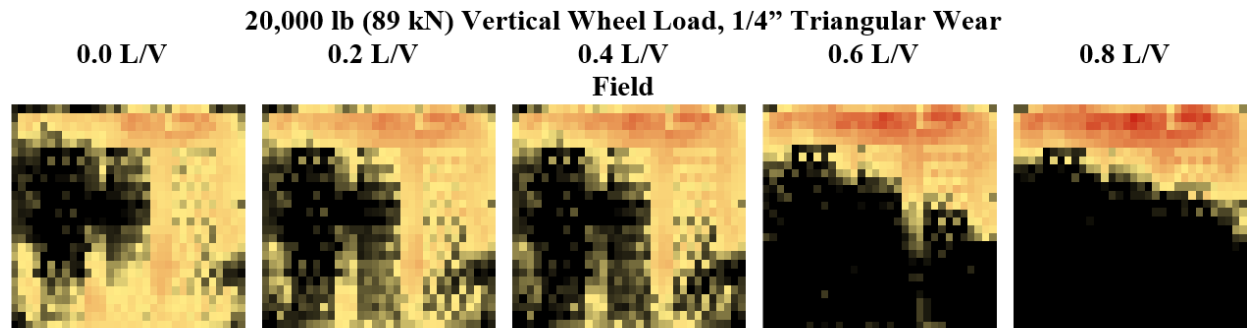
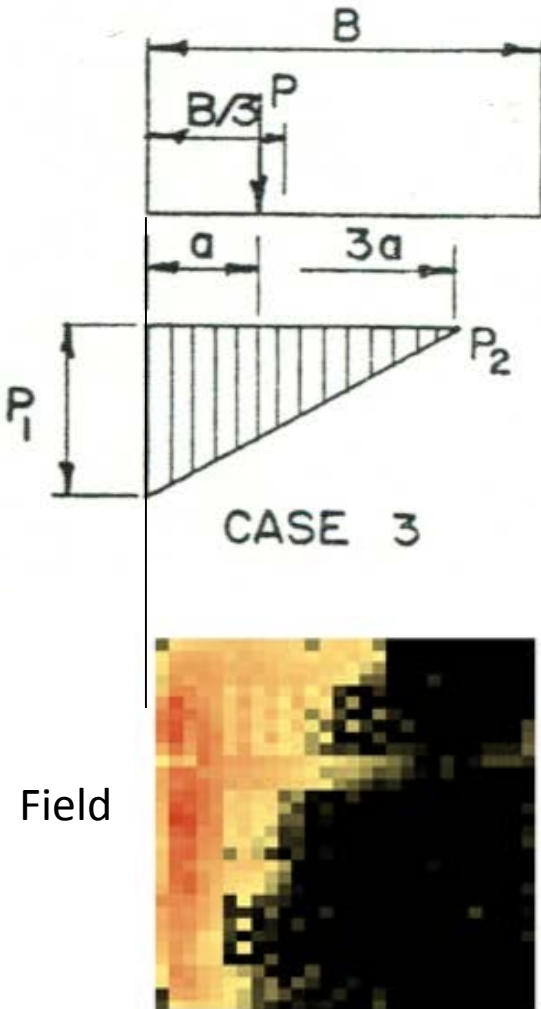

Increasing Pressure

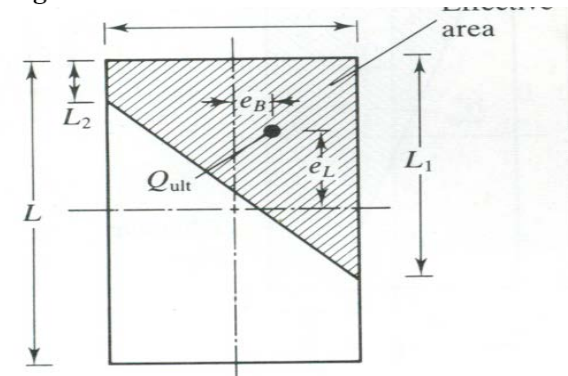

Data from Greve et al., 2015  
 – TRB paper.

# Tie Vibration and Tie Support

## Frequency Response Functions

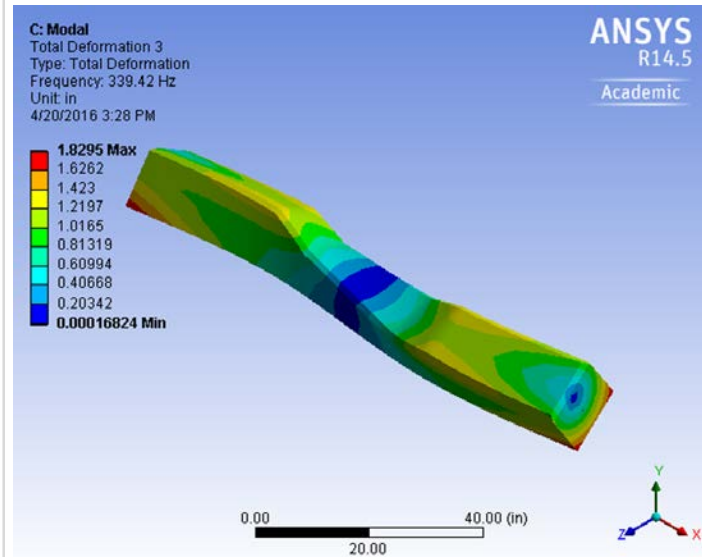
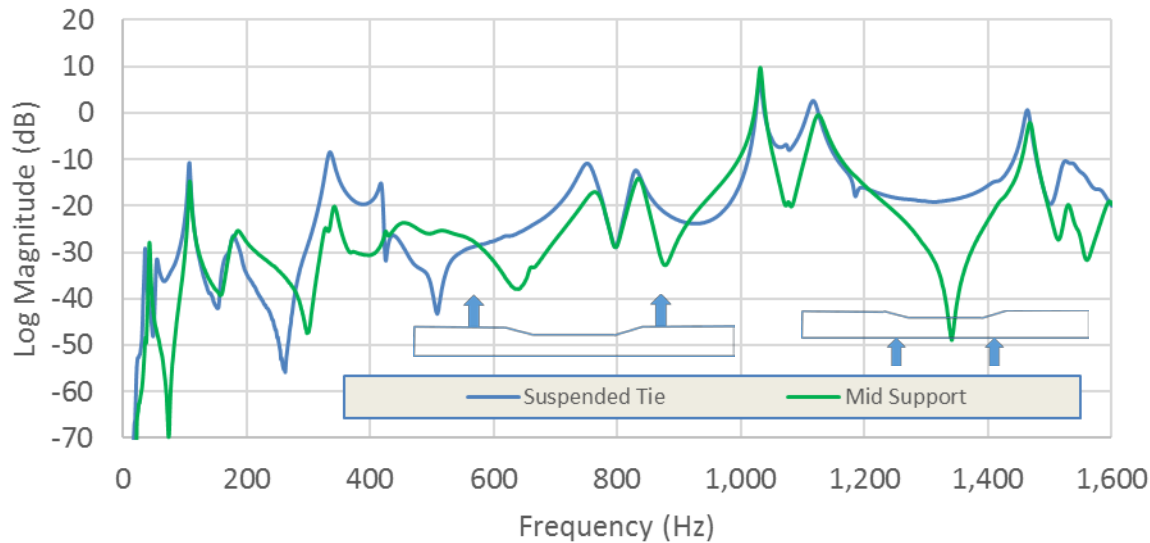

# Tie Support Conditions

## Tie Deformation and Load Under Differing Support Conditions

### Exaggerated Deflection

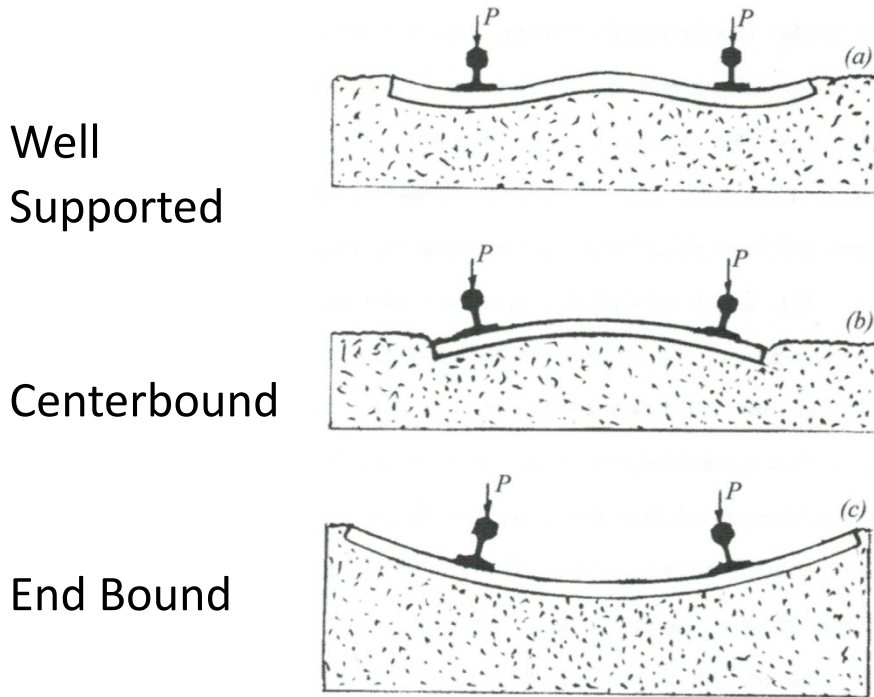

### Tie Bearing Pressure

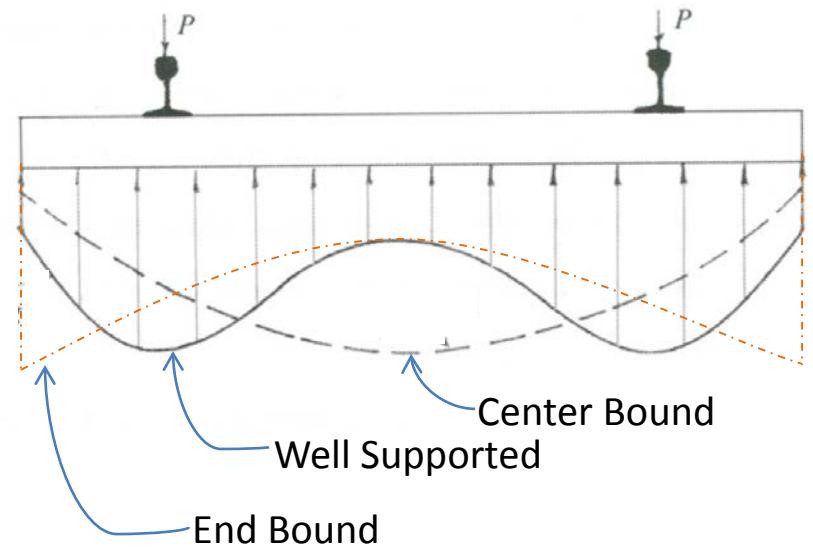

Adapted from Kerr (2003).

# Tie Support Problems

## Tie Type – Ballast Pressure Considerations

### Wood

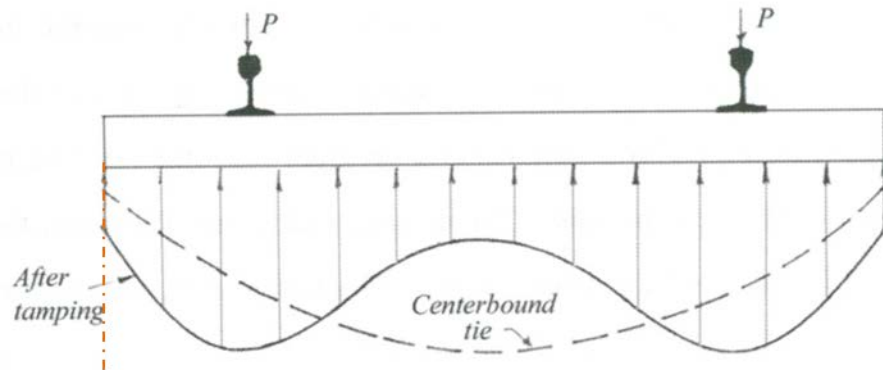

### Concrete

- ❑ Stress Distribution



- ❑ Stiff Foundation over soft layer
- ❑ Solution: Tamp



# Mayville et al., 2012



# Tie Site A – Cracked Ties – 0.5 in. Deflection



Muddy Ballast, tie cavity  
Indicative of tie movement/slack



Cracked Tie (moment cracks)

Horizontal Split

# Problems for Ballast

## Track Support Problems

- ❑ Track Load Redistribution
- ❑ Ballast Rearrangement
- ❑ Track Geometry



Inspection: GPR (Ground Penetrating Radar)

- Clean Ballast Depth, Moisture
- Longitudinal Variations

## Tie Bearing Capacity Problems

- Tie and Rail Loads
- Cross Level and Geometry
- Track Position Movement



Inspection: Seismic (SASW)

- Resilient Modulus
- Density

# Ballast Settlement with Increased Fouling

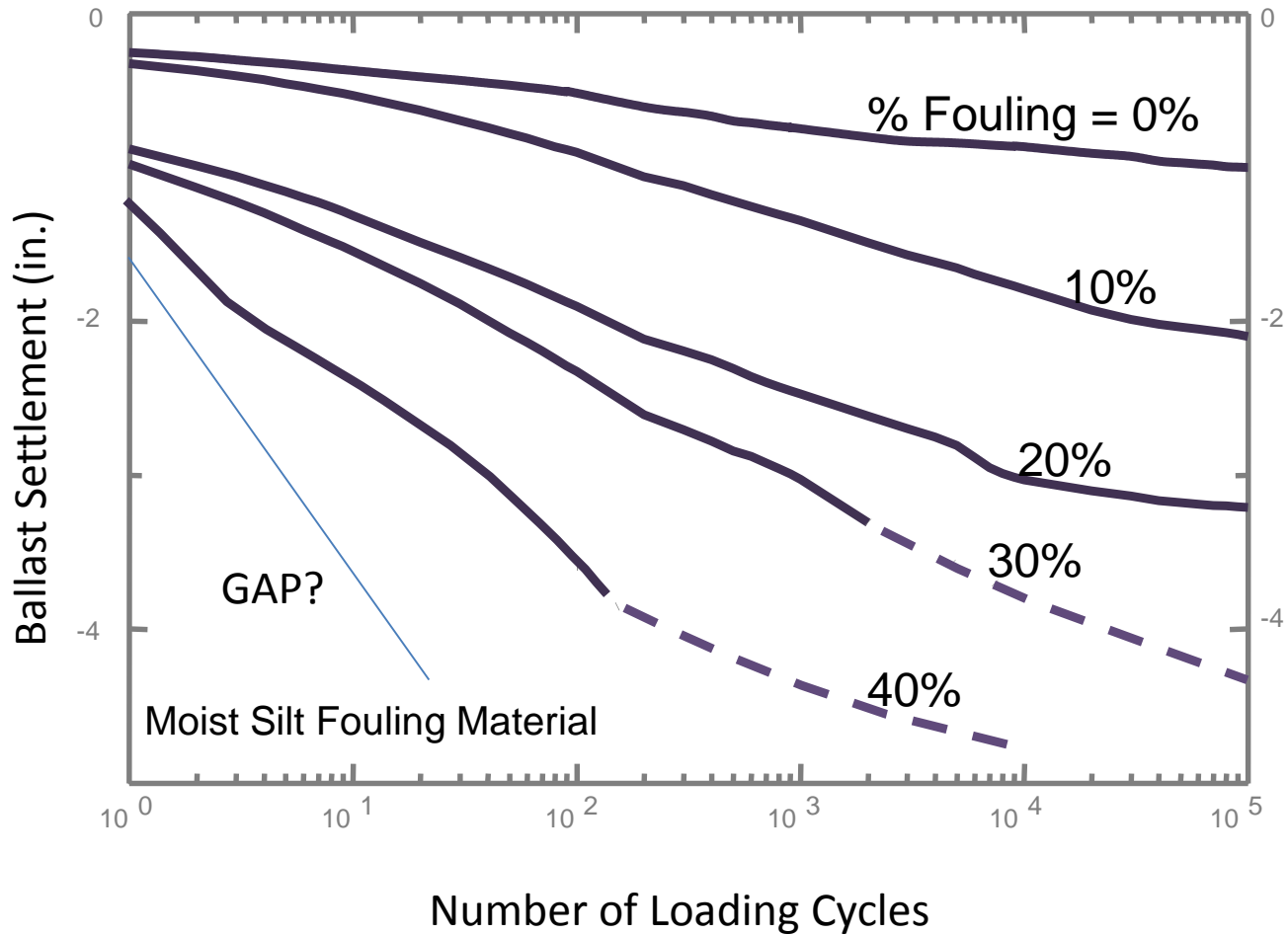

Selig and Waters, 1994

# Effect of Material Quality on Granular Behavior (Freeme & Servas, 1985)

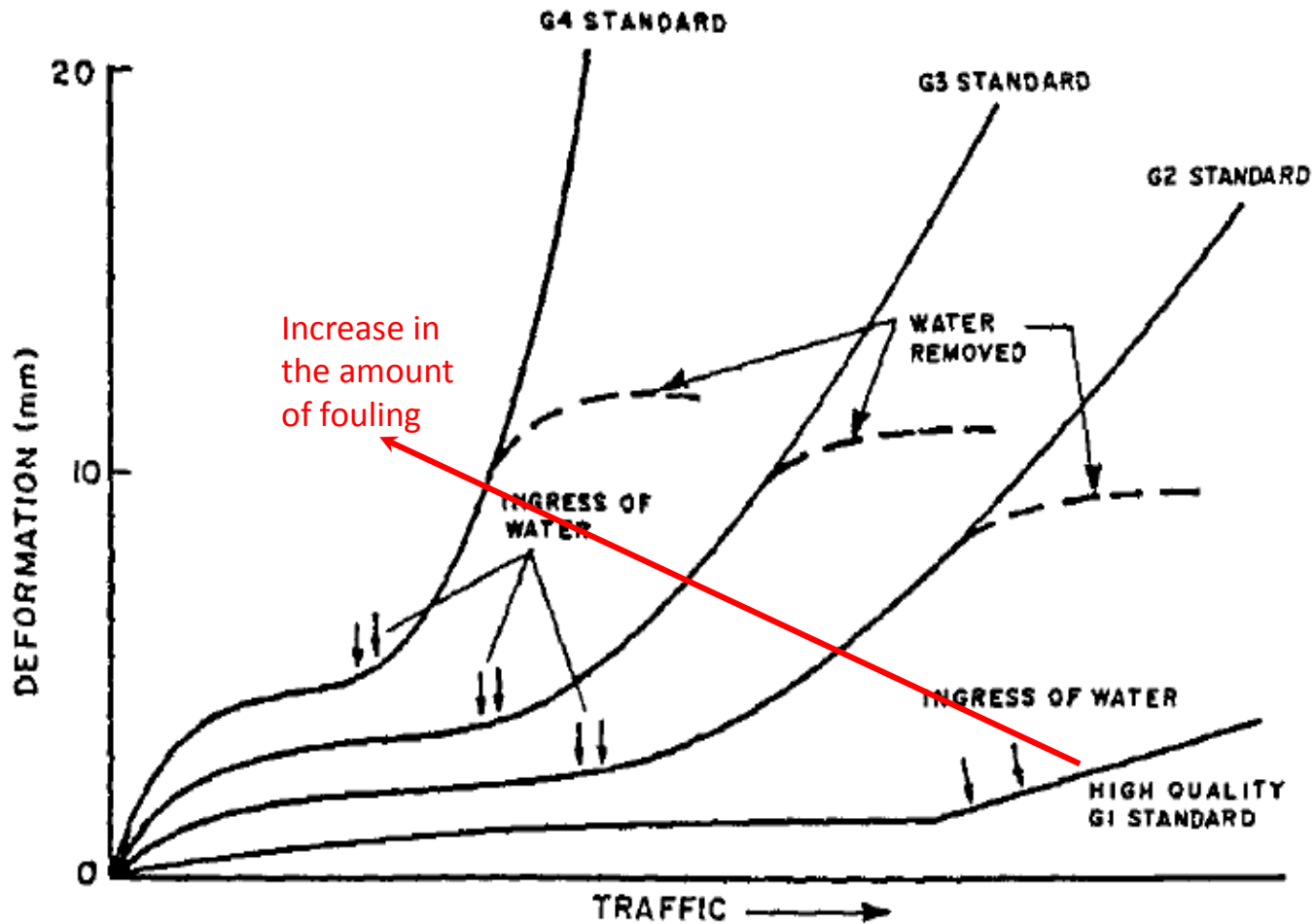

# Track Structure Design Specifications

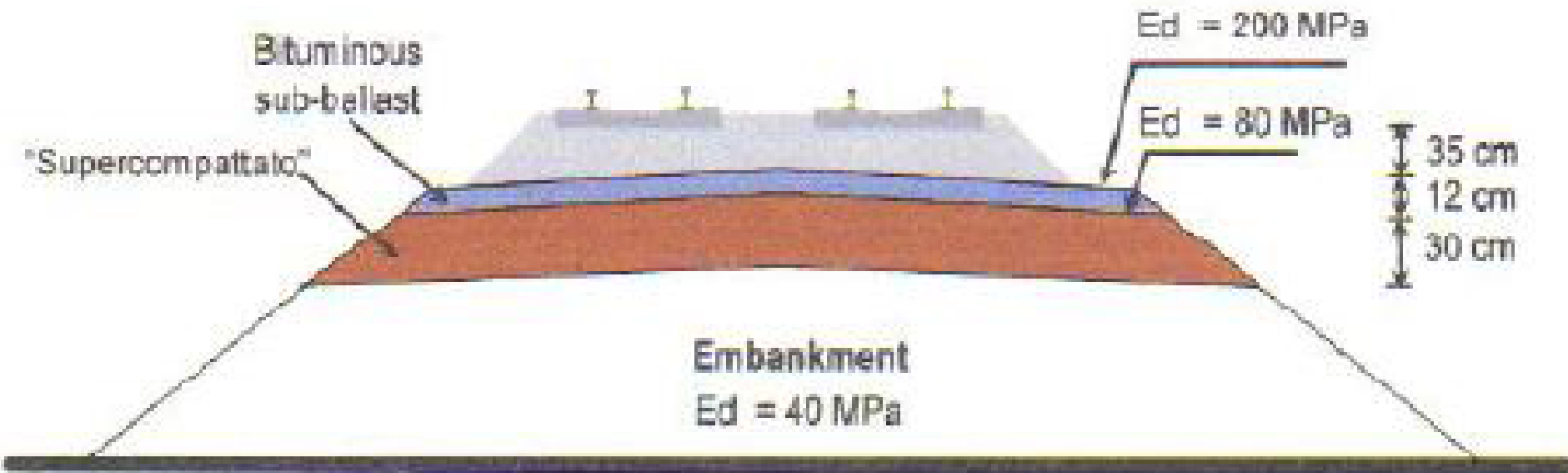

Source: J. Rose AREMA 2015

# Field Track Support Assessment – Diagnosis and QA / QC

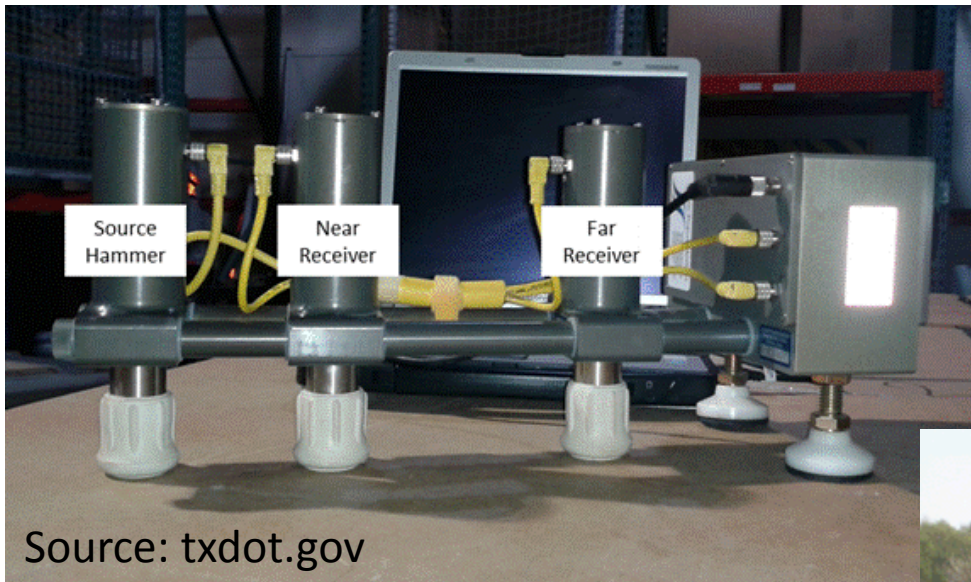

**Seismic Property Analyzer –  
Spectral Analysis of Surface  
Waves (SASW)**

Source: fhwa.dot.gov

**Lightweight  
Deflectometer (LWD)**



# Summary

- ❑ Track system design
  - Rail-tie-ballast
- ❑ Optimized track stiffness
  - QA/QC parameters
- ❑ Maintenance QA
  - Drainage
  - Defection uniformity
- ❑ Operational Controls
  - Wheel load
  - Precipitation

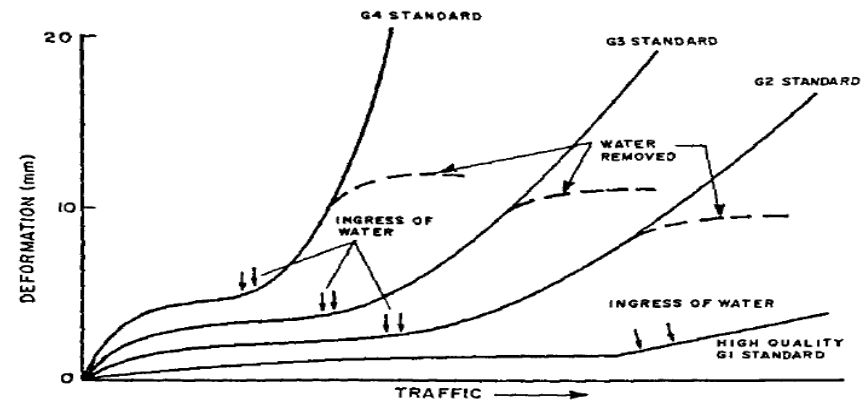
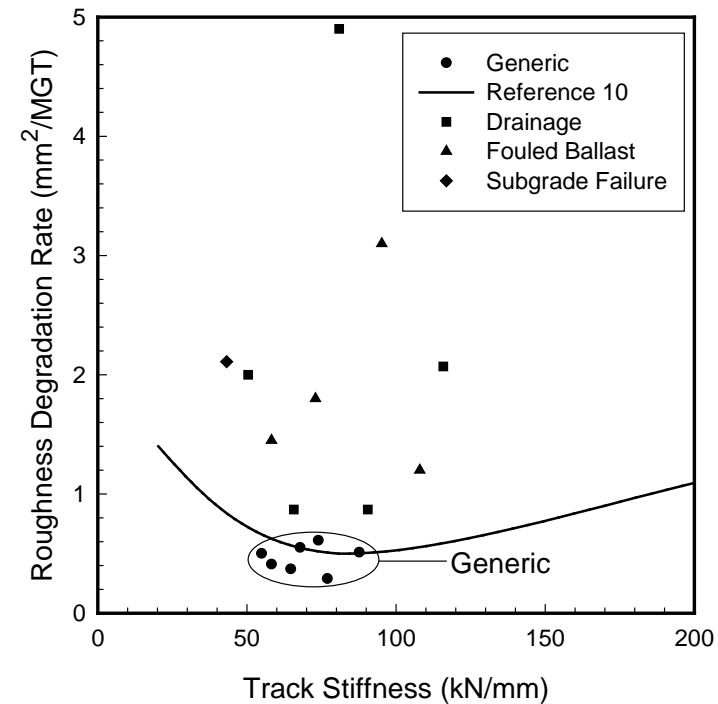

# If Not Identified and Corrected, Poor Track Support May Cause...

