

Validating Finite Element Model with Field Data



**FRA Tie and Fastening System BAA - Industry Partners Meeting
Incline Village, NV
7 October 2013**

Professor Bassem O. Andrawes, George Zhe Chen and Moochul Shin



U.S. Department of Transportation
Federal Railroad Administration

RAILTEC
UNIVERSITY OF ILLINOIS AT URBANA-CHAMPAIGN

Outline

- Role of Finite Element (FE) analysis in mechanistic design
- Methodology and background for FE Analysis – global and detailed model
- FE models for field experiments
 - Displacement calibration
 - Load distribution validation
- Applications for the calibrated models
- Conclusions
- Future work

Overall project deliverables

Mechanistic Design Framework

Literature Review

Load Path Analysis

International Standards

Current Industry Practices

AREMA Chapter 30

I – TRACK

Statistical Analysis
from FEM

Free Body Diagram
Analysis

Probabilistic Loading

Finite Element Model

Laboratory Experimentation

Field Experimentation

Parametric Analyses

Methodology for FE analysis

- Model development
 - Component model
 - Single-tie model
 - Multiple-tie model
- Model calibration
 - Displacement measurement
 - Strain measurement
- Model validation
 - Vertical load distribution
 - Lateral load distribution
- Model application
 - Parametric studies
 - Simplified tool

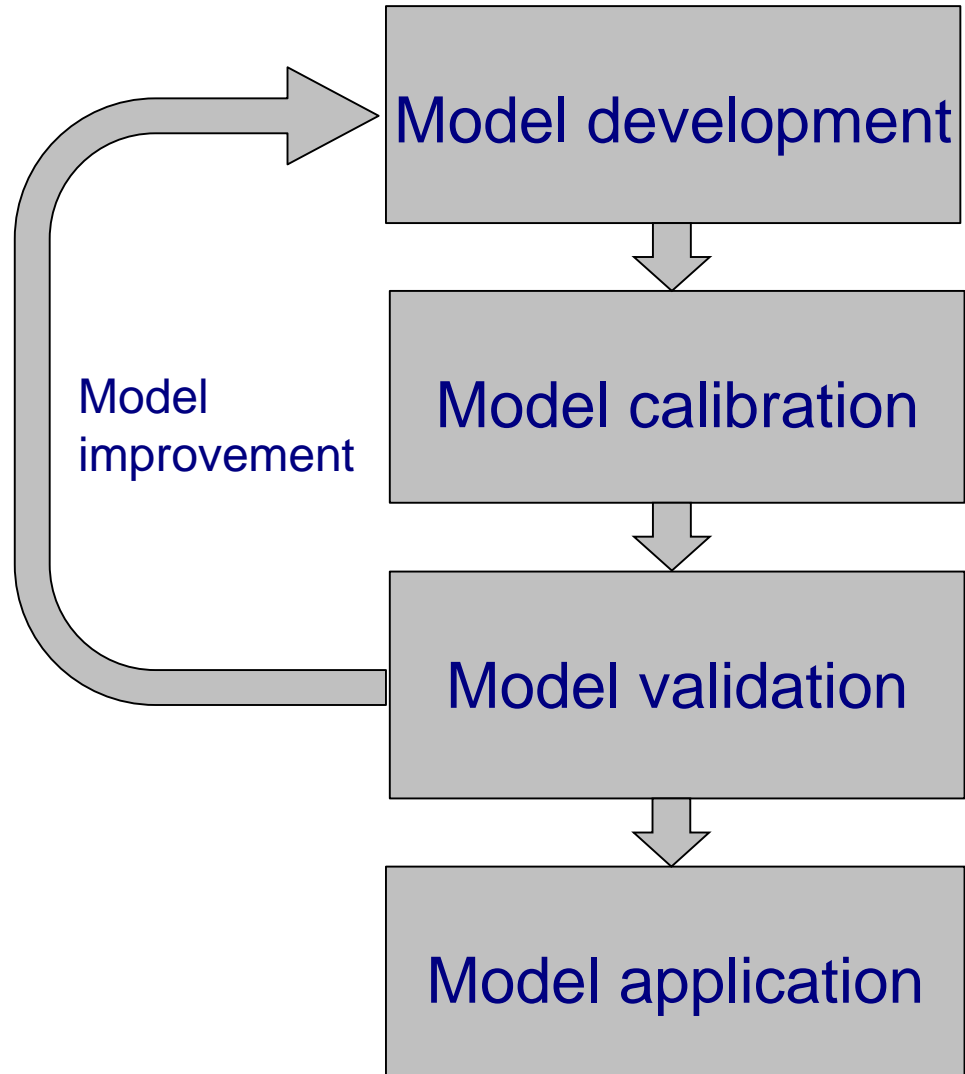

Review of model development: component model

Component Validation

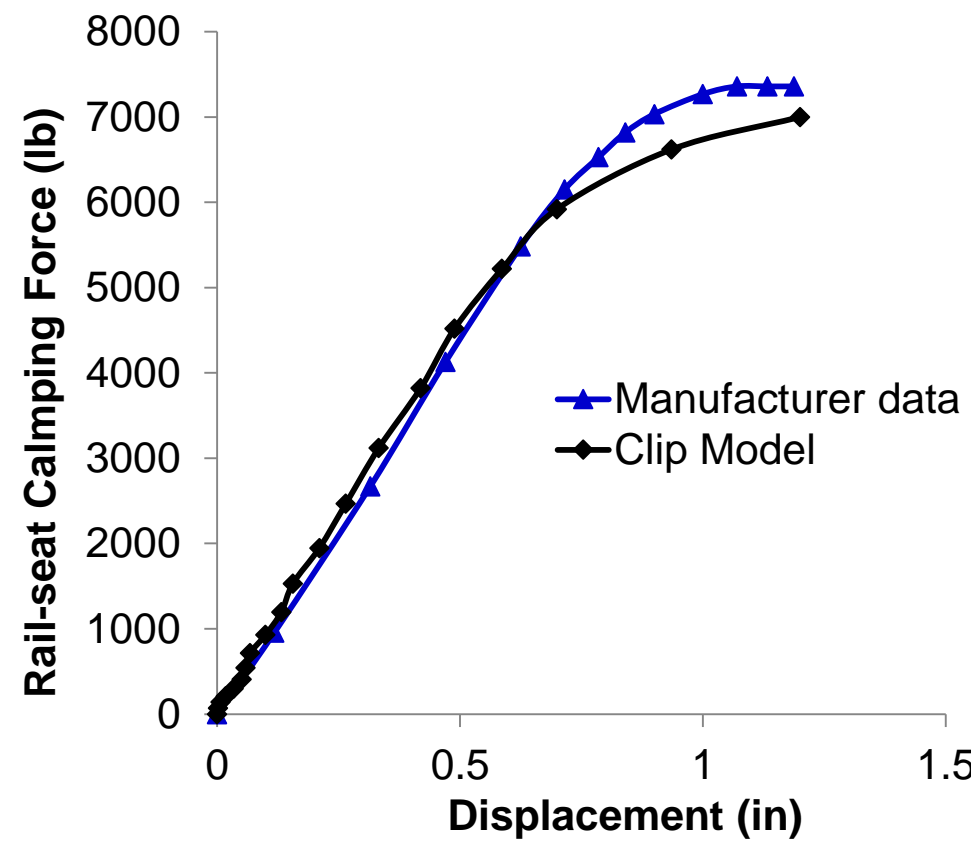
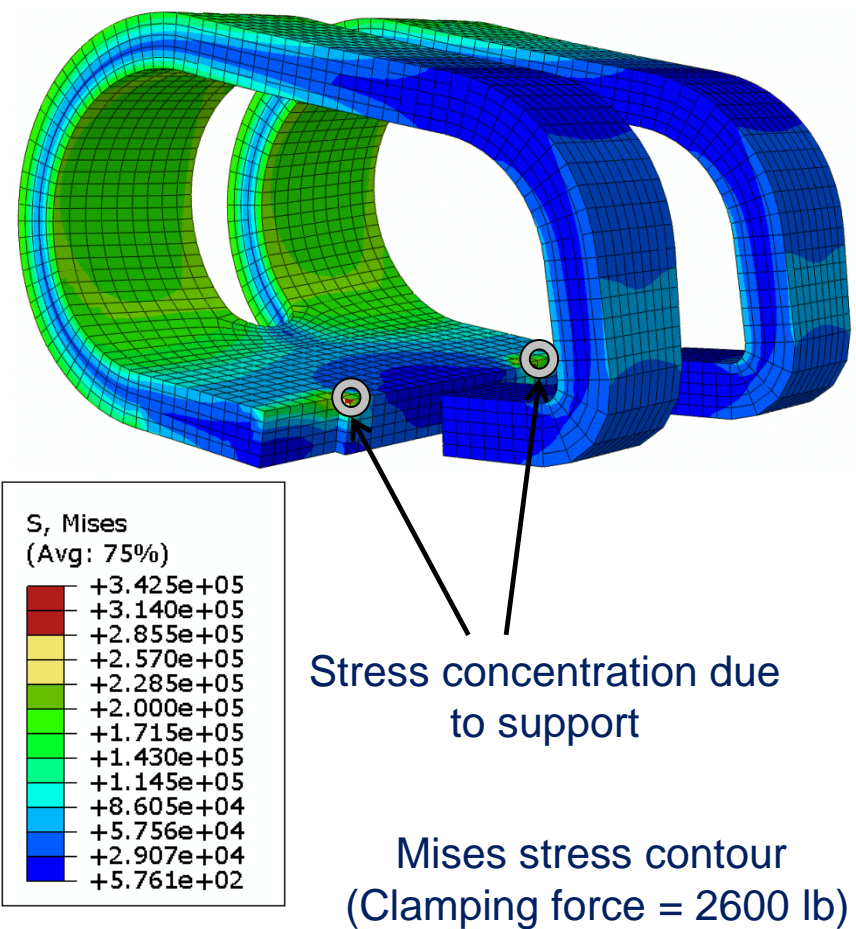

Review of model development: system model

Laboratory Test Validation

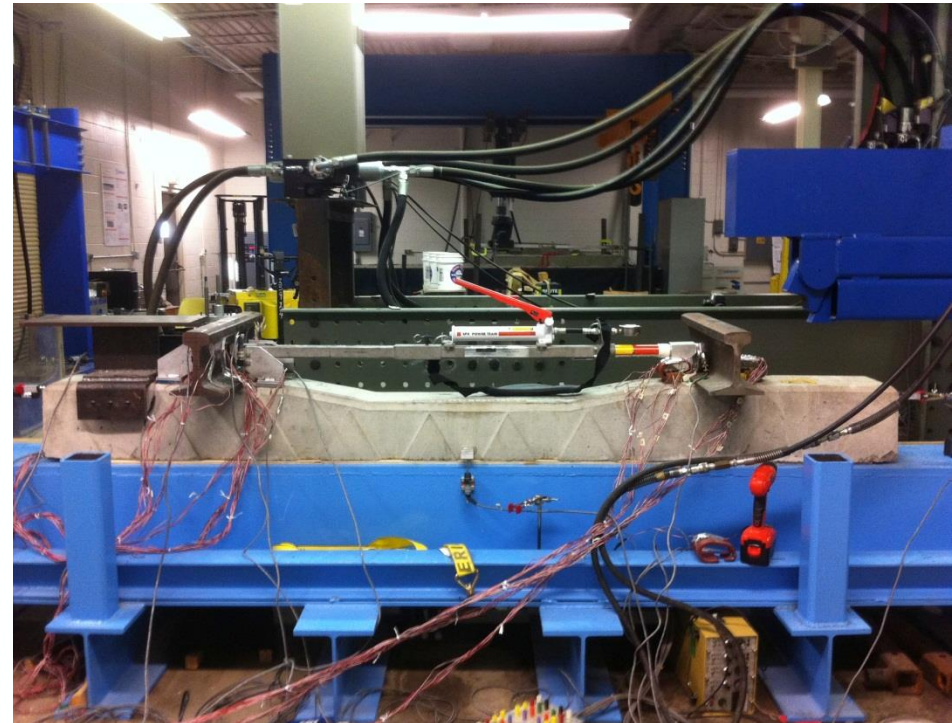
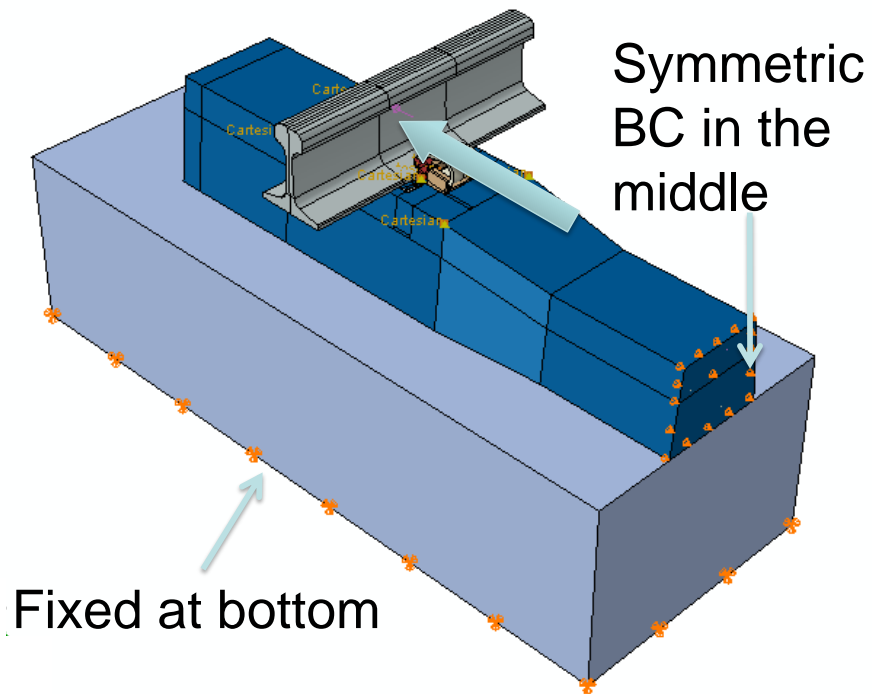

FE models for field experiment

- Two symmetric models with identical loads are used to simulate the behavior of track in the field:
 - Global model includes five crossties and fastening systems along with substructure support
 - Detailed model includes a single crosstie and fastening system with substructure support

Global model

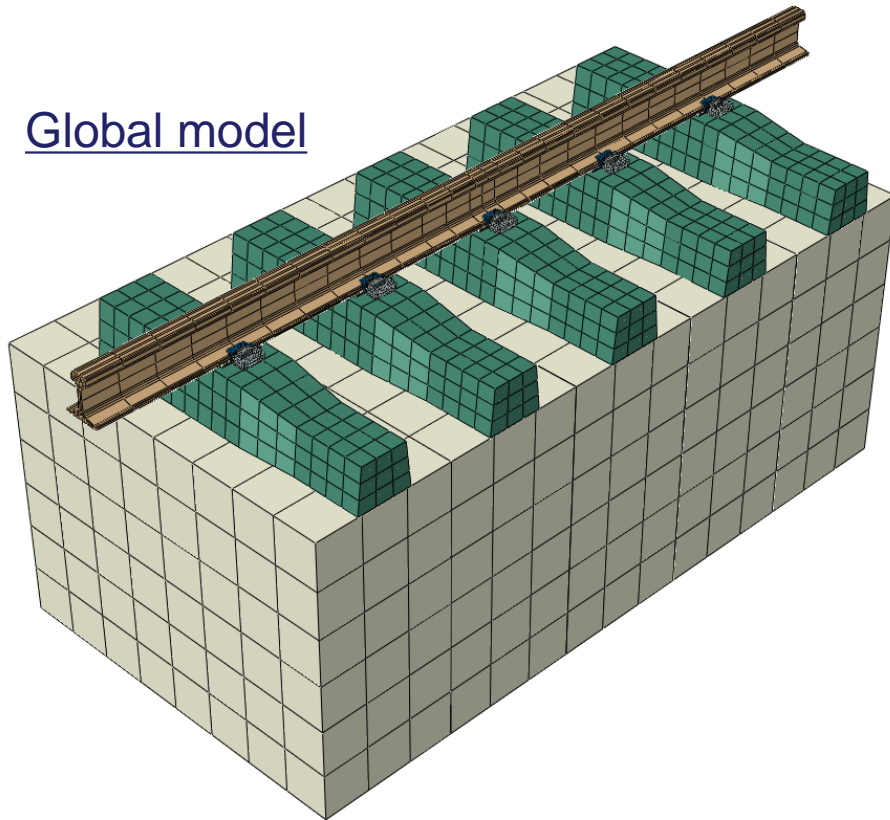

Detailed model

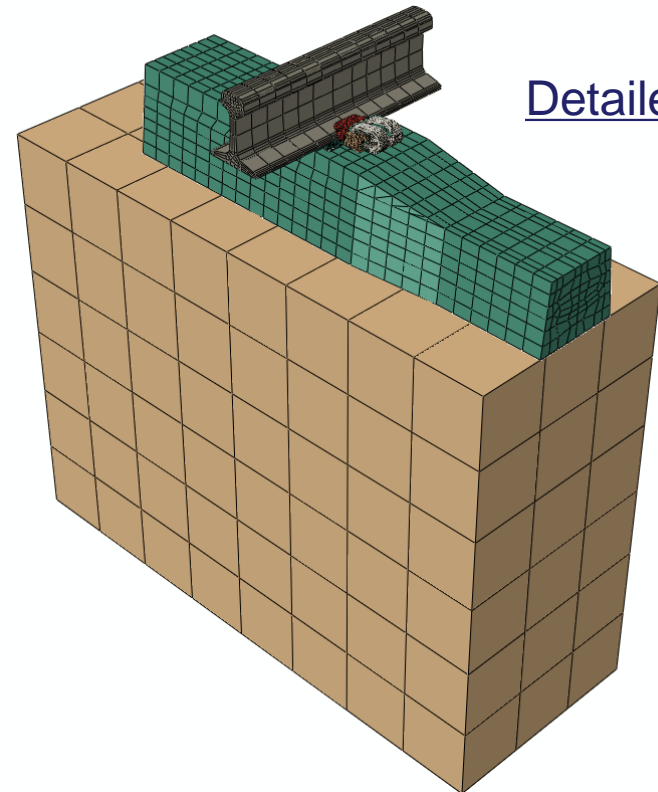

FE models for field experiment

- Global model simulates the system-level track behavior
- The displacement at the end of rail segment in the detailed model is the same as that in the global model (submodel technique)
- The combination of the two models capture the global behavior of the track system, and provide accurate prediction close to the loading point within a reasonable calculation time

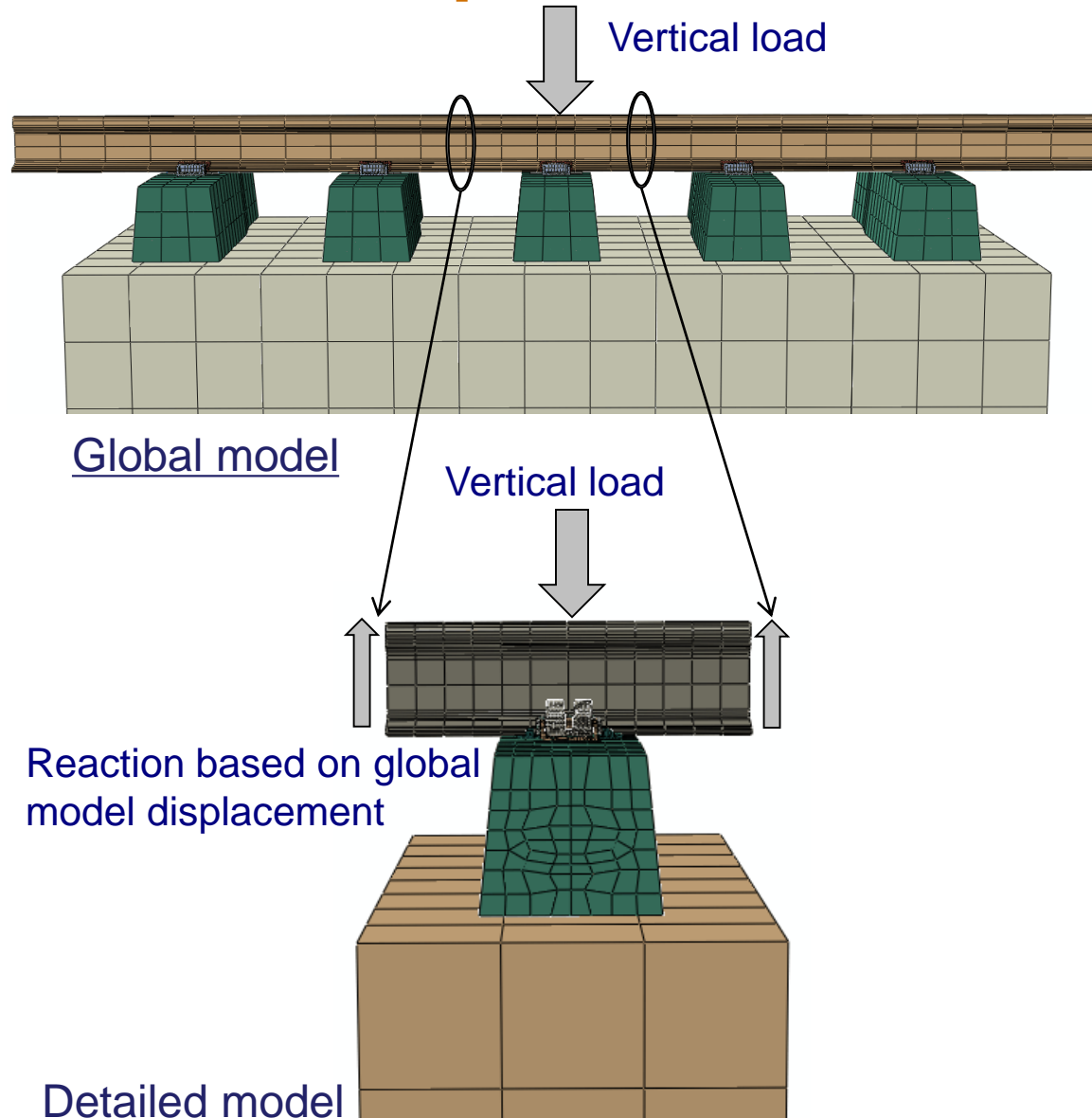

FE models for field experiment: global model

- Global model includes five crossties and fastening systems
- Clamping forces are represented with pressure
- Coarse mesh is defined and component geometry is simplified

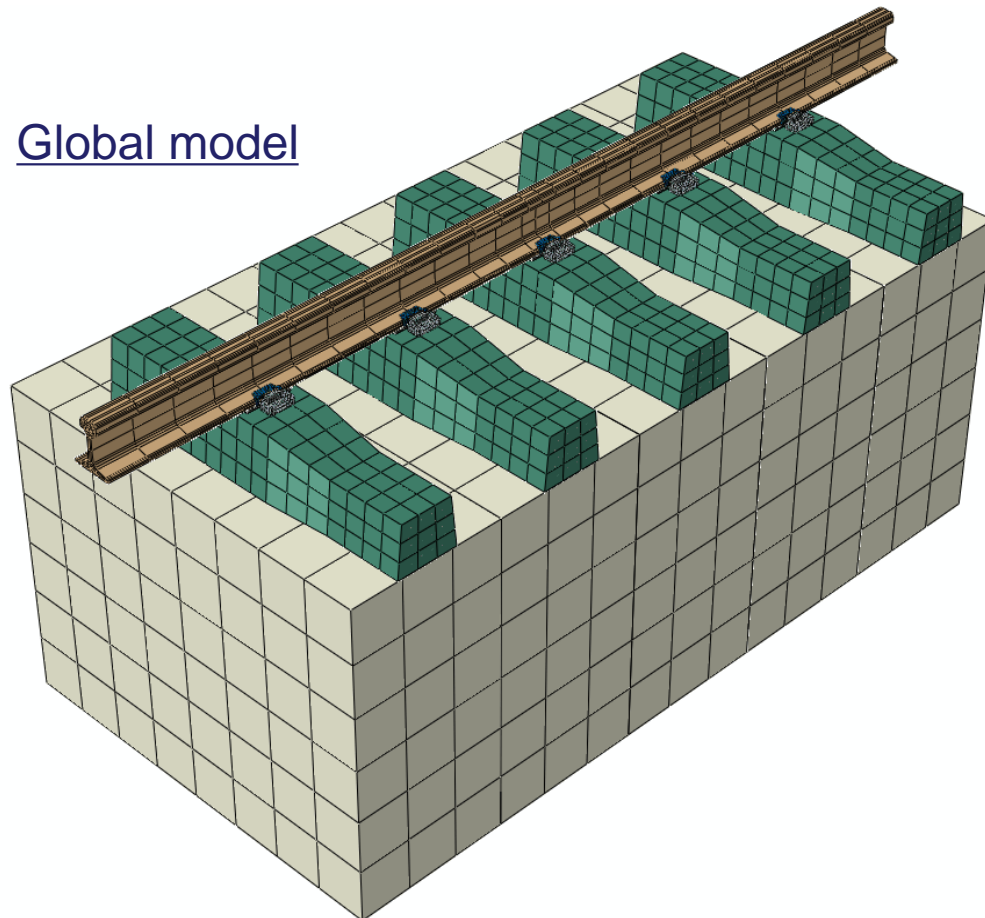

FE models for field experiment: global model

- Global model includes five crossties and fastening systems
- Clamping forces are represented with pressure
- Coarse mesh is defined and component geometry is simplified

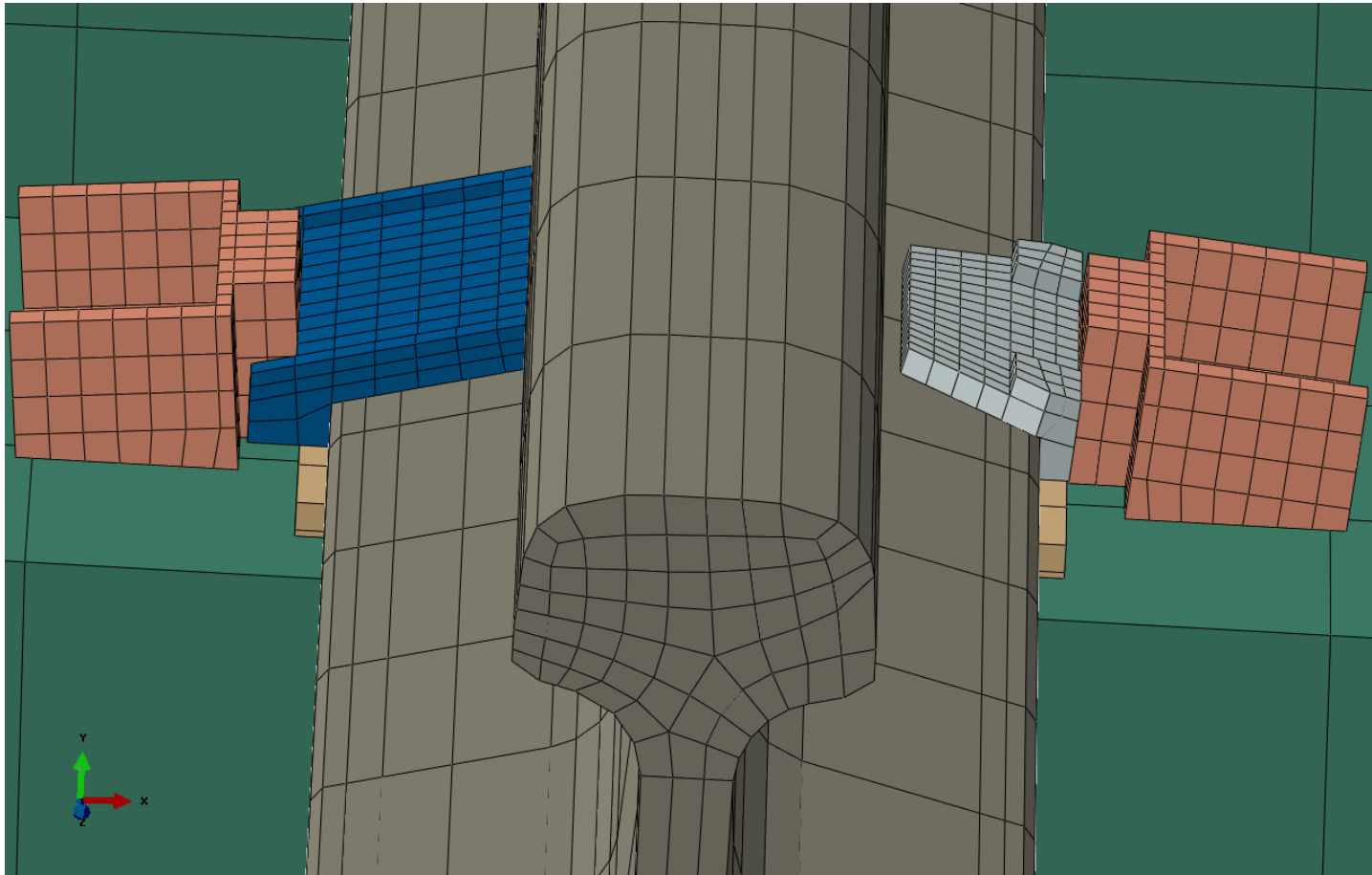

FE models for field experiment: global model

- Global model includes five crossties and fastening systems
- Clamping forces are represented with pressure
- Coarse mesh is defined and component geometry are simplified

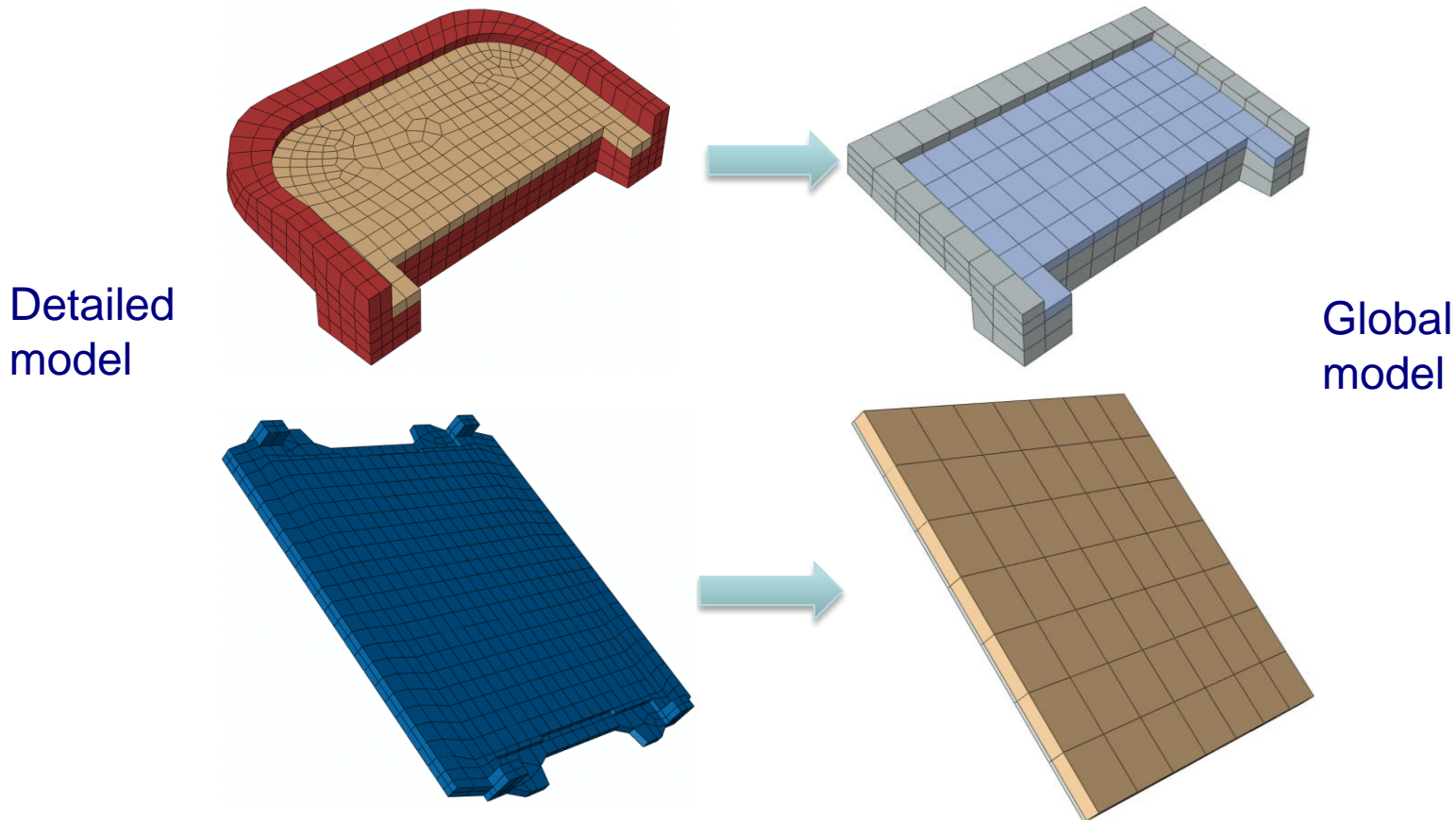

FE models for field experiment: detailed model

- Detailed model simulates the center crosstie and fastening system in the global model
- Displacement at the end of rail segment is the same as global model
- Fine mesh is defined, and clamping force is simulated by inserting the clips

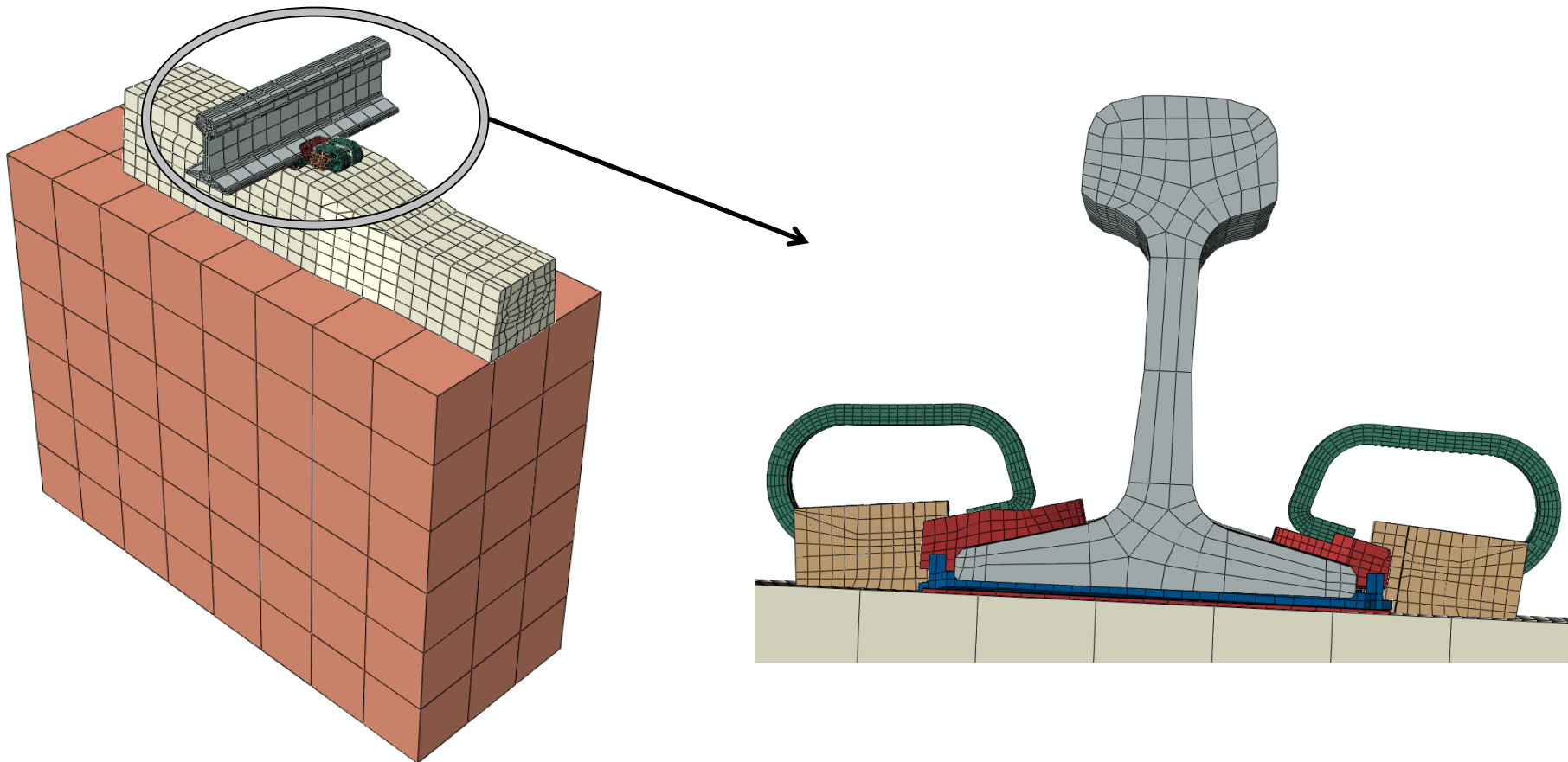

Model calibration based on field experiment results

- Vertical behavior of the model is calibrated based on vertical crosstie displacement measurements from field experiment at TTC
- The measurements are from static test using the Track Loading Vehicle (TLV) on the Railroad Test Track (RTT)



Model calibration based on field experiment results

- Vertical behavior of the model is calibrated based on vertical crossie displacement measurements from field experiment at TTC
- The measurements are from static test using the Track Loading Vehicle (TLV) on the Railroad Test Track (RTT)

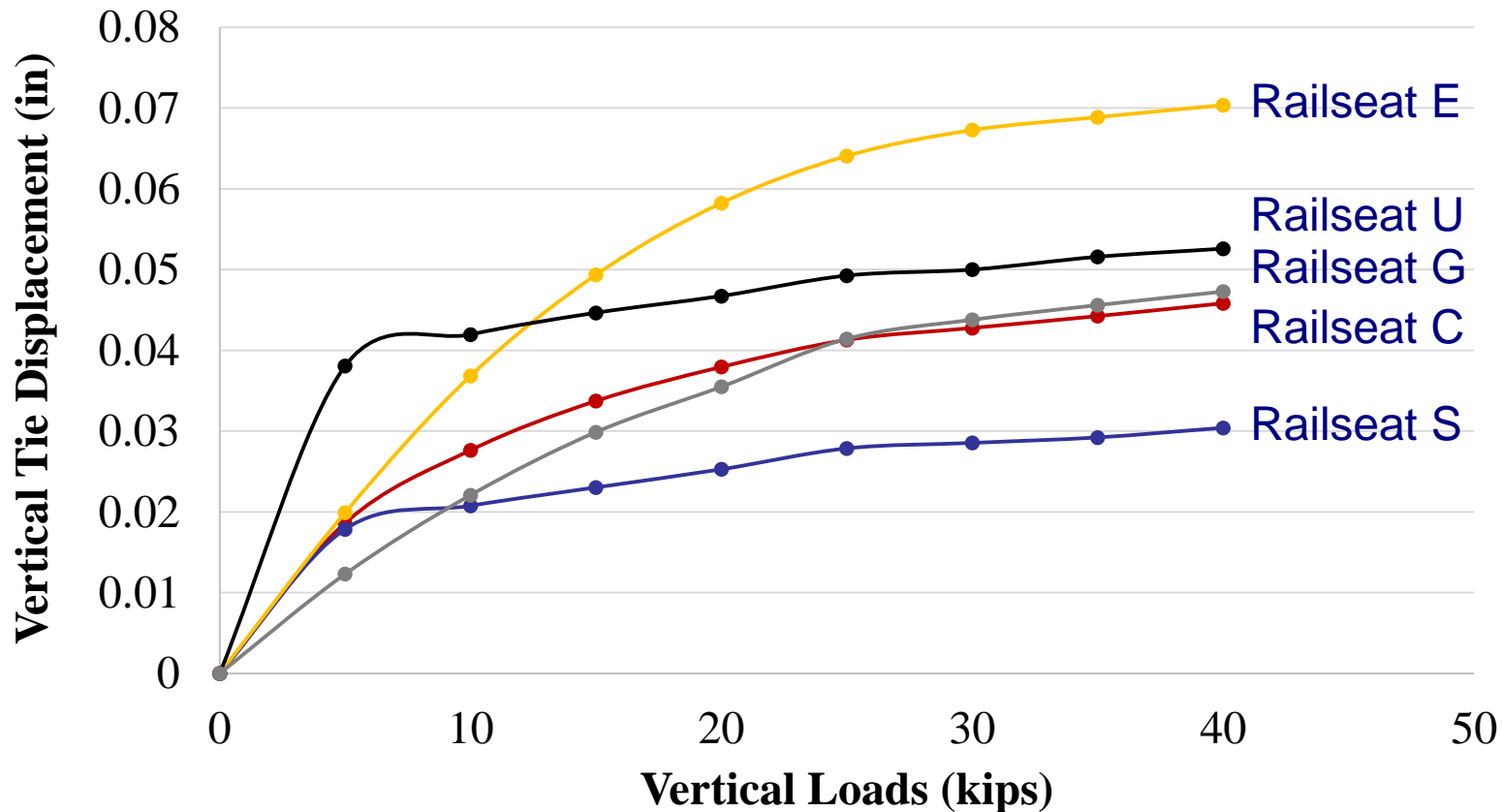

Model calibration based on vertical displacement measurement

- A block is modeled as a general support for the track system to represent the ballast, subballast, and subgrade
- Hyperelastic material model is defined for the block, and it is calibrated to match the displacement measurement

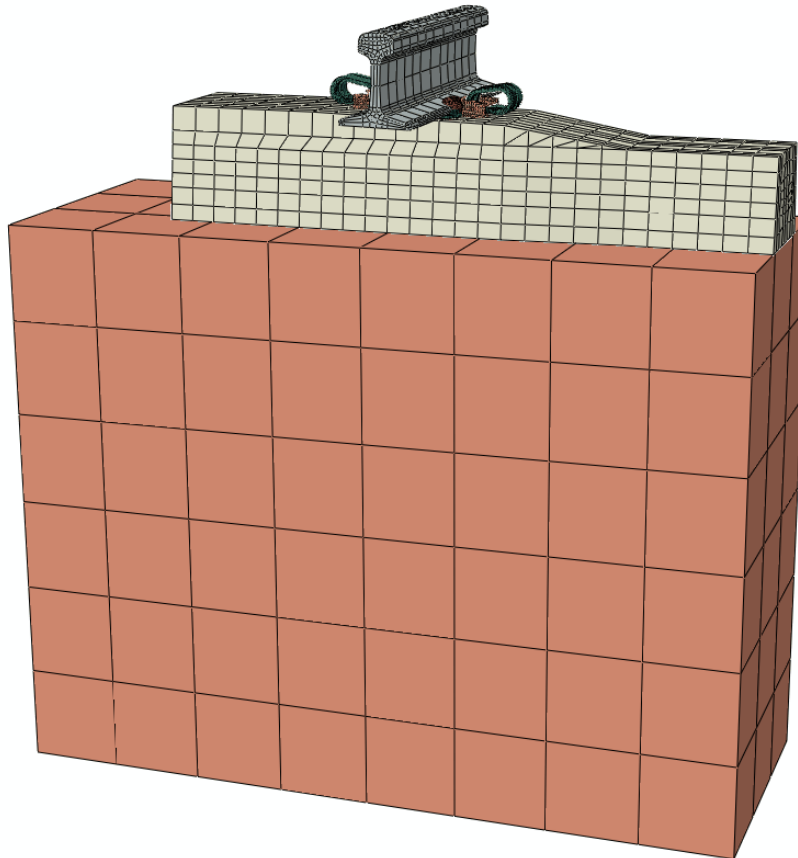

Model calibration based on vertical displacement measurement

- A block is modeled as a general support for the track system to represent the ballast, subballast, and subgrade
- Hyperelastic material model is defined for the block, and it is calibrated to match the displacement measurement

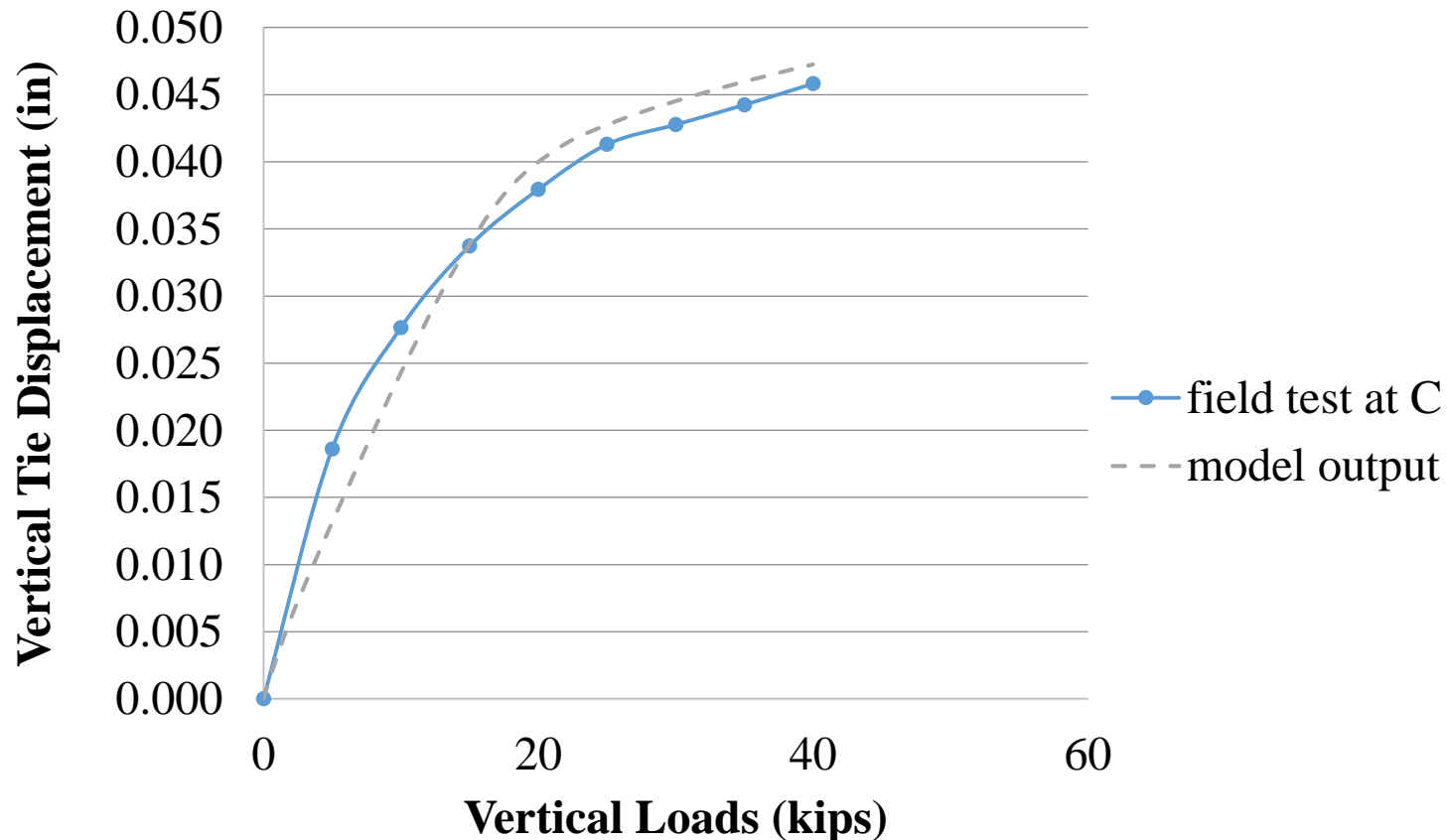

Model calibration based on lateral displacement measurement

- Lateral behavior of the model is calibrated based on lateral rail displacement measurements from field experiment at TTC
- The measurements are from static tests using the Track Loading Vehicle (TLV) on the Railroad Test Track (RTT)



Model calibration based on lateral displacement measurement

- Lateral behavior of the model is calibrated based on lateral rail displacement measurements from field experiment at TTC
- The measurements are from static tests using the Track Loading Vehicle (TLV) on the Railroad Test Track (RTT)



Model calibration based on lateral displacement measurement

- Lateral behavior of the model is calibrated based on lateral rail displacement measurements from field experiment at TTC
- The measurements are from static test using the Track Loading Vehicle (TLV) on the Railroad Test Track (RTT)

TLV at V=40 and varying lateral loads

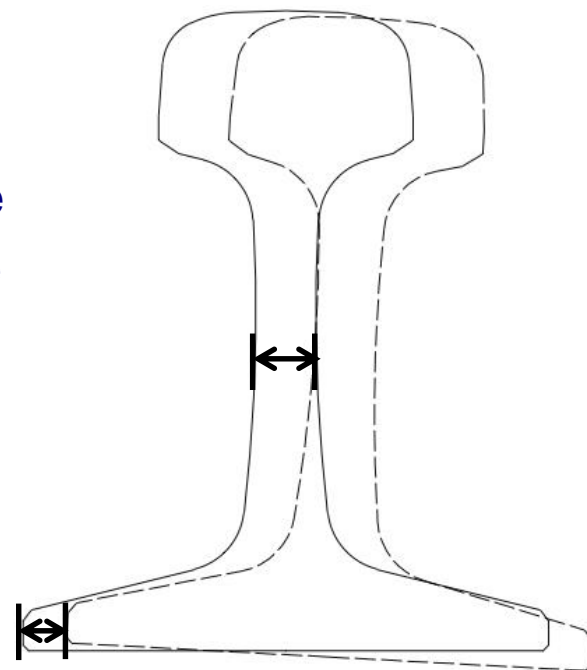
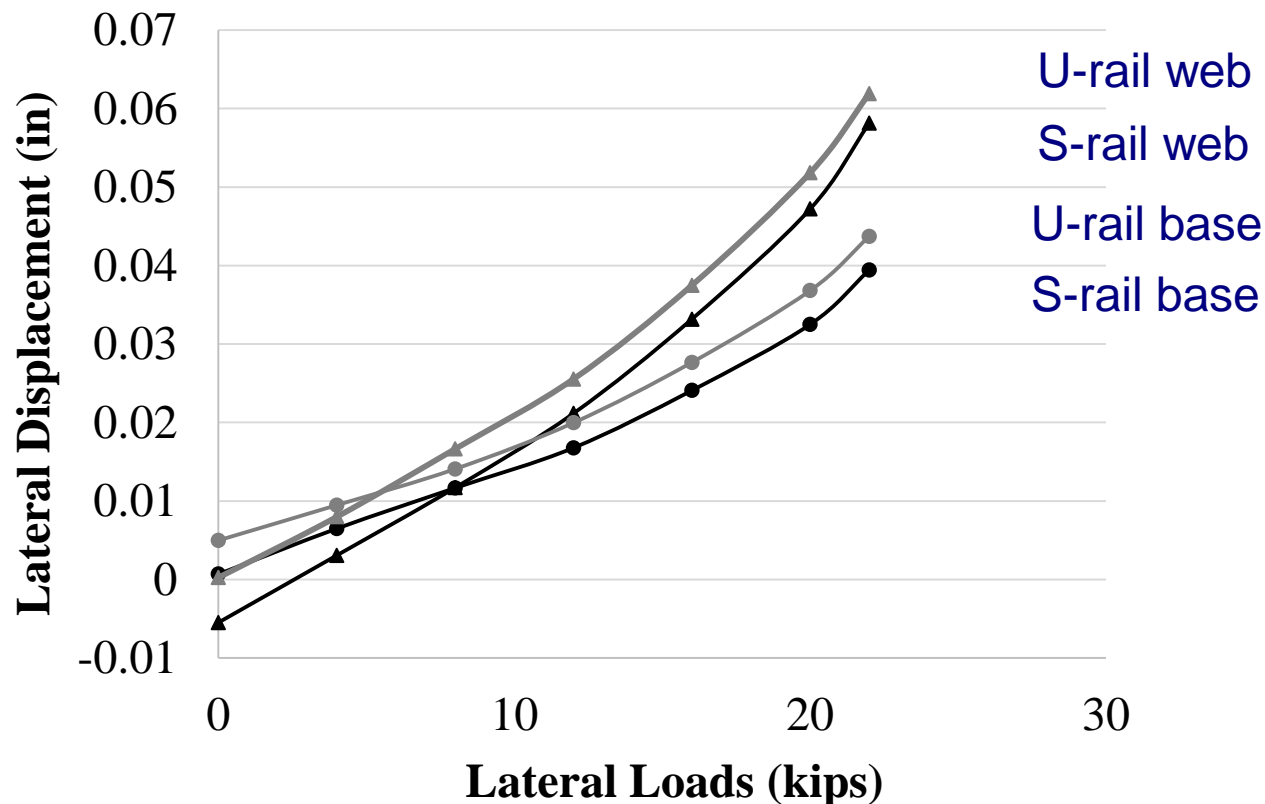

Model calibration based on lateral displacement measurement

- As during the static test of TLV on tangent track, identical vertical and lateral loads were applied on each rail, the crossties were in tension
- Symmetric boundary condition is defined at the section of crosstie
- The lateral behavior of the model is calibrated by the property of interaction between concrete and shoulder

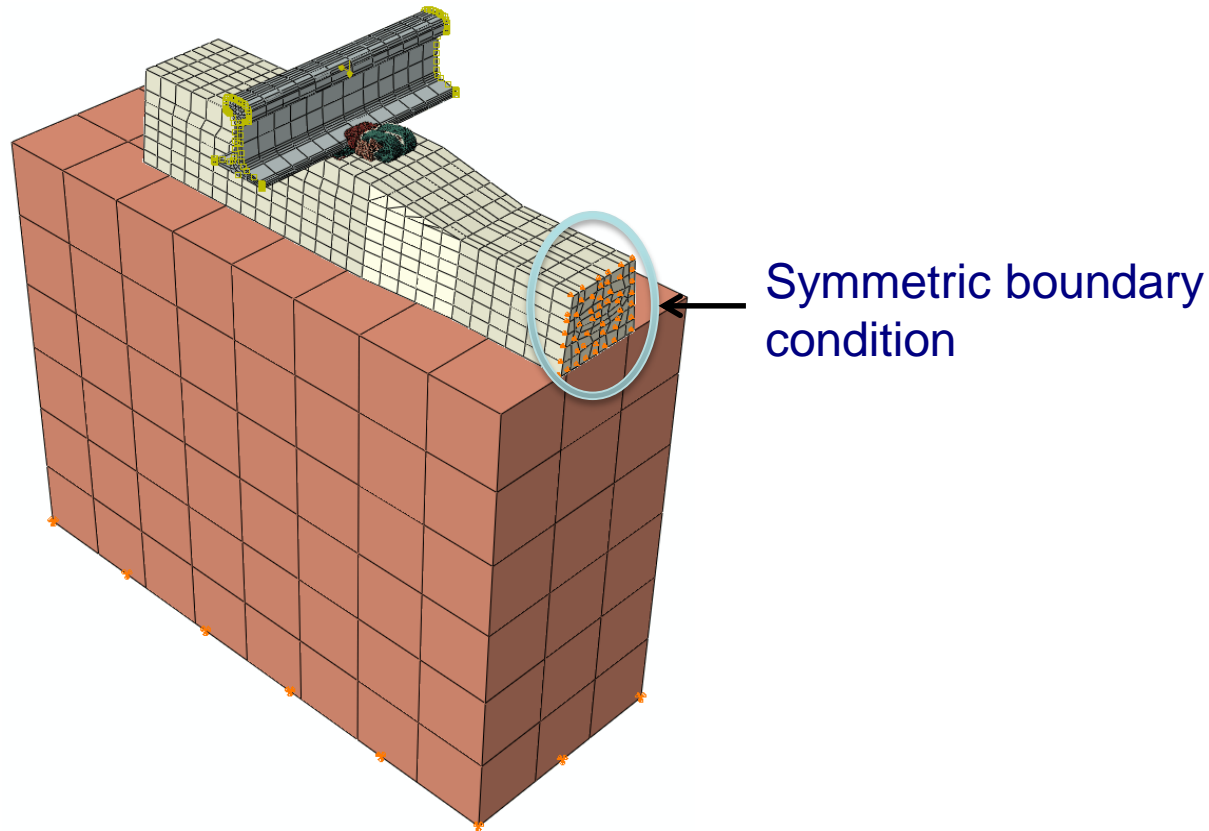

Model calibration based on lateral displacement measurement

- As during the static test of TLV on tangent track, identical vertical/lateral load was applied on each rail, the crossties were in tension
- Symmetric boundary condition is defined at the section of crosstie
- The lateral behavior of the model is calibrated by the property of interaction between concrete and shoulder

TLV at V=40 and varying lateral loads

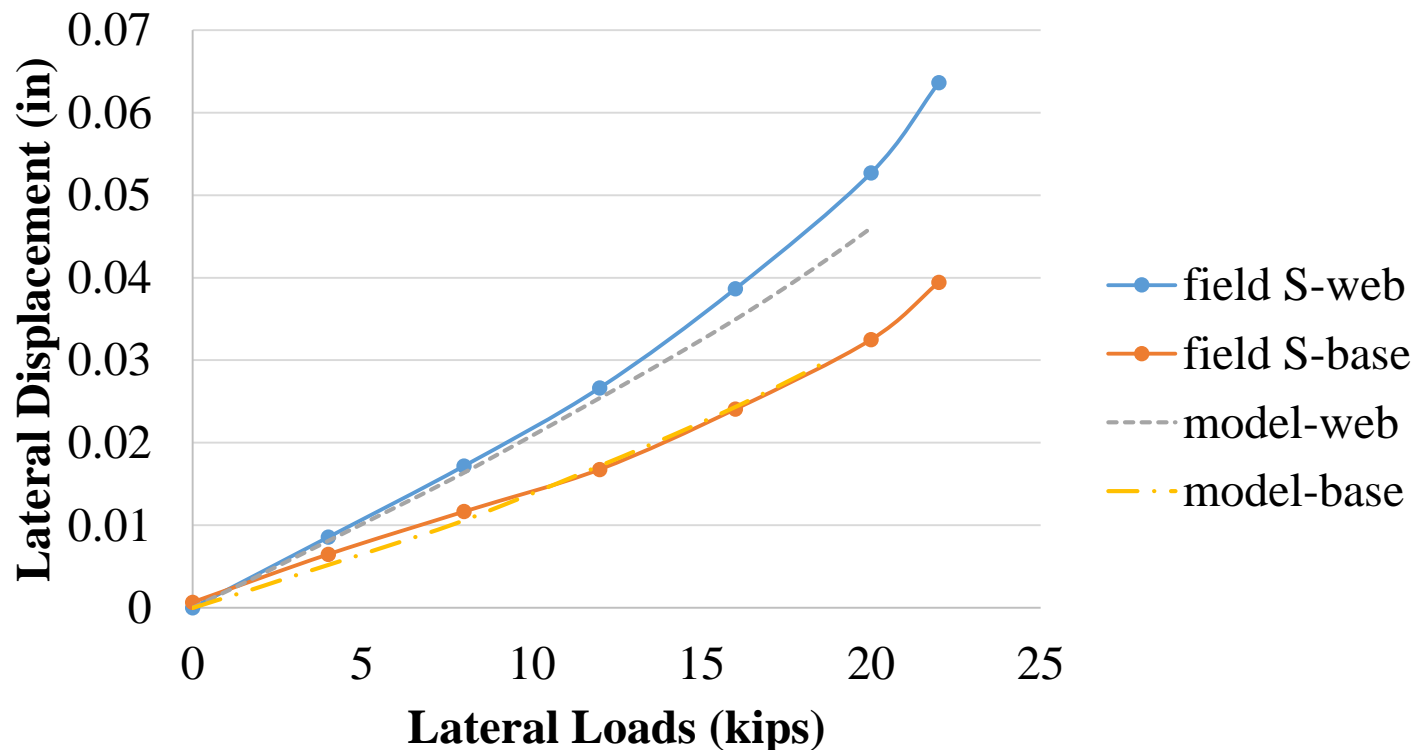

Vertical load distribution-field data

- The vertical/lateral load distribution based on model output is also compared with test measurements, and similar distribution is observed
- The model vertical load distribution is compared with the shear force measurement based on chevron gauge pairs
- Due to tie-to-tie variability in support condition, some difference is observed

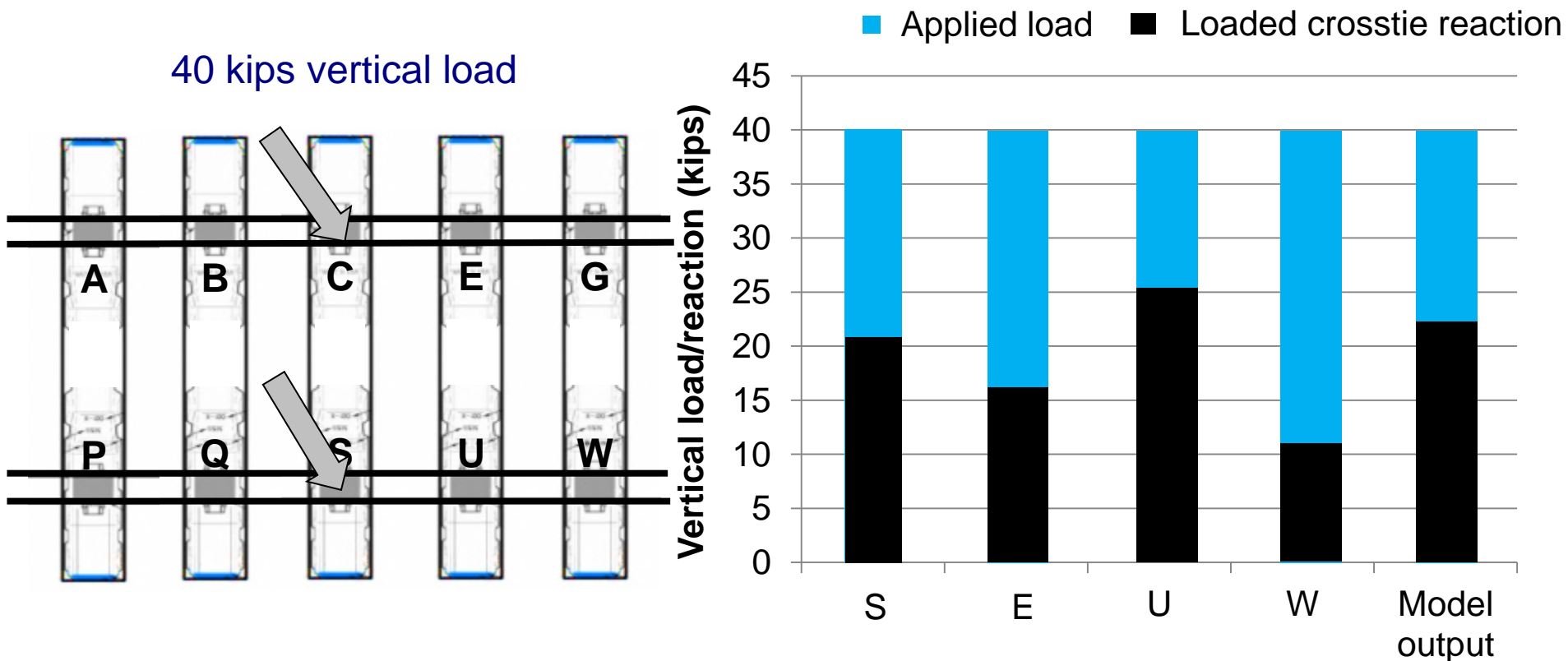

Vertical load distribution-calibrated model

- The vertical/lateral load distribution based on model output is also compared with test measurements, and similar distribution is observed
- The model vertical load distribution is compared with the shear force measurement based on chevron gauge pairs
- Due to tie-to-tie variability in support condition, some difference is observed

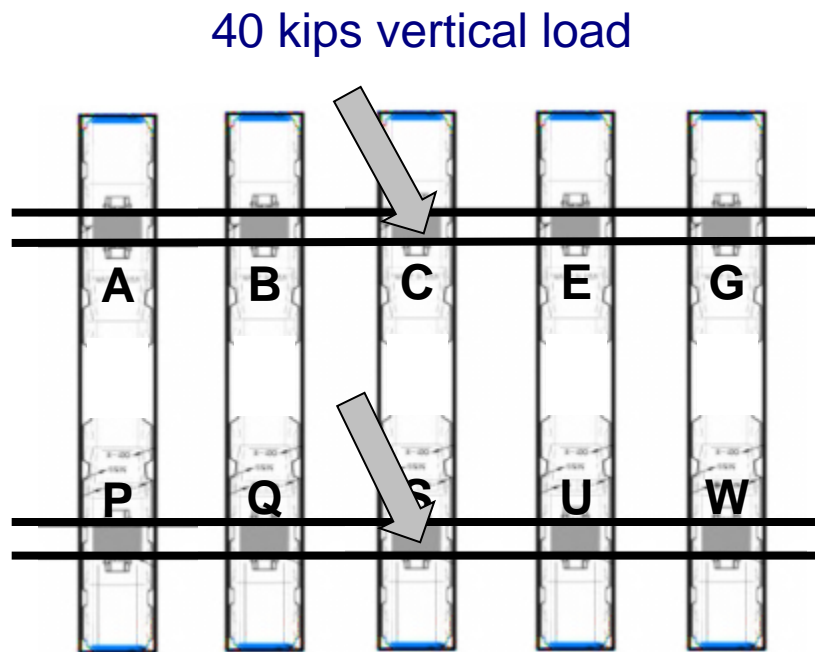

**Rail seat vertical load
model output (kips)**

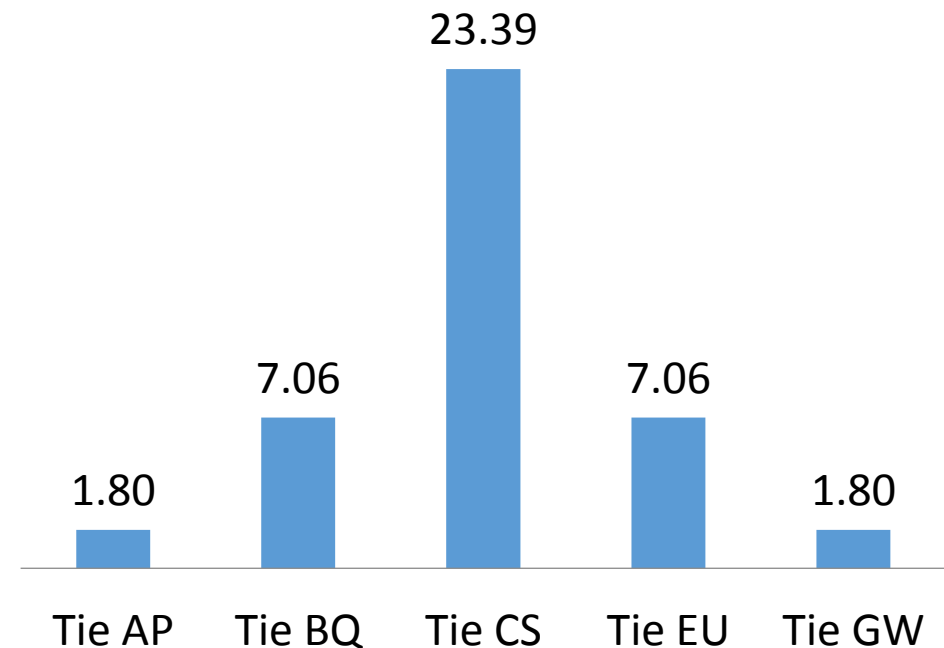

Lateral load distribution-field data

- the FE model lateral load distribution is compared with measurement of shoulder beam insert

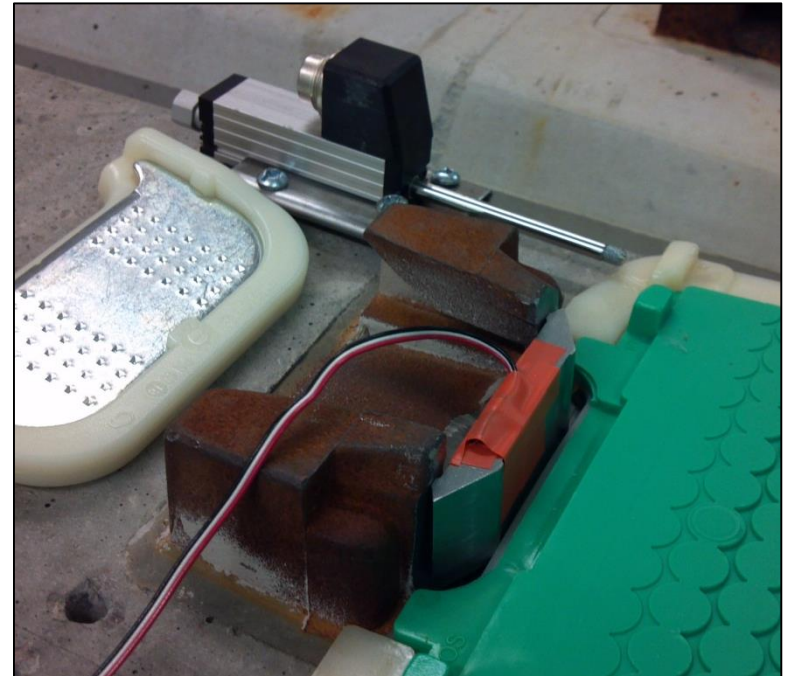
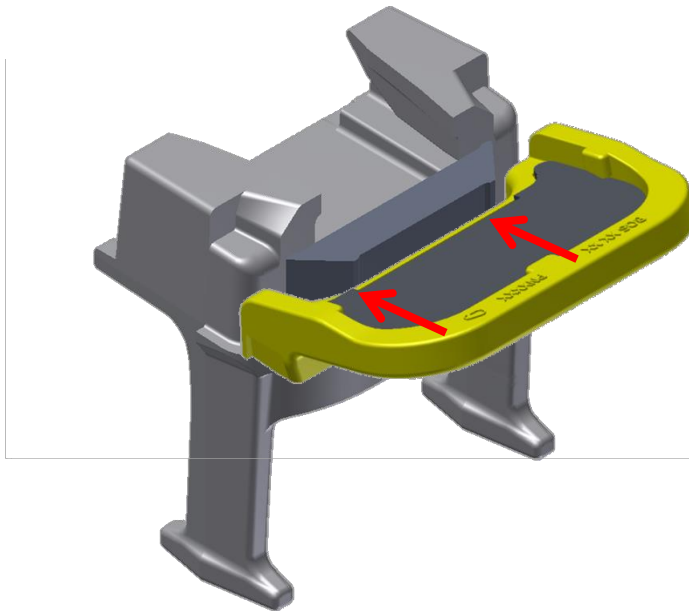

Lateral load distribution-field data

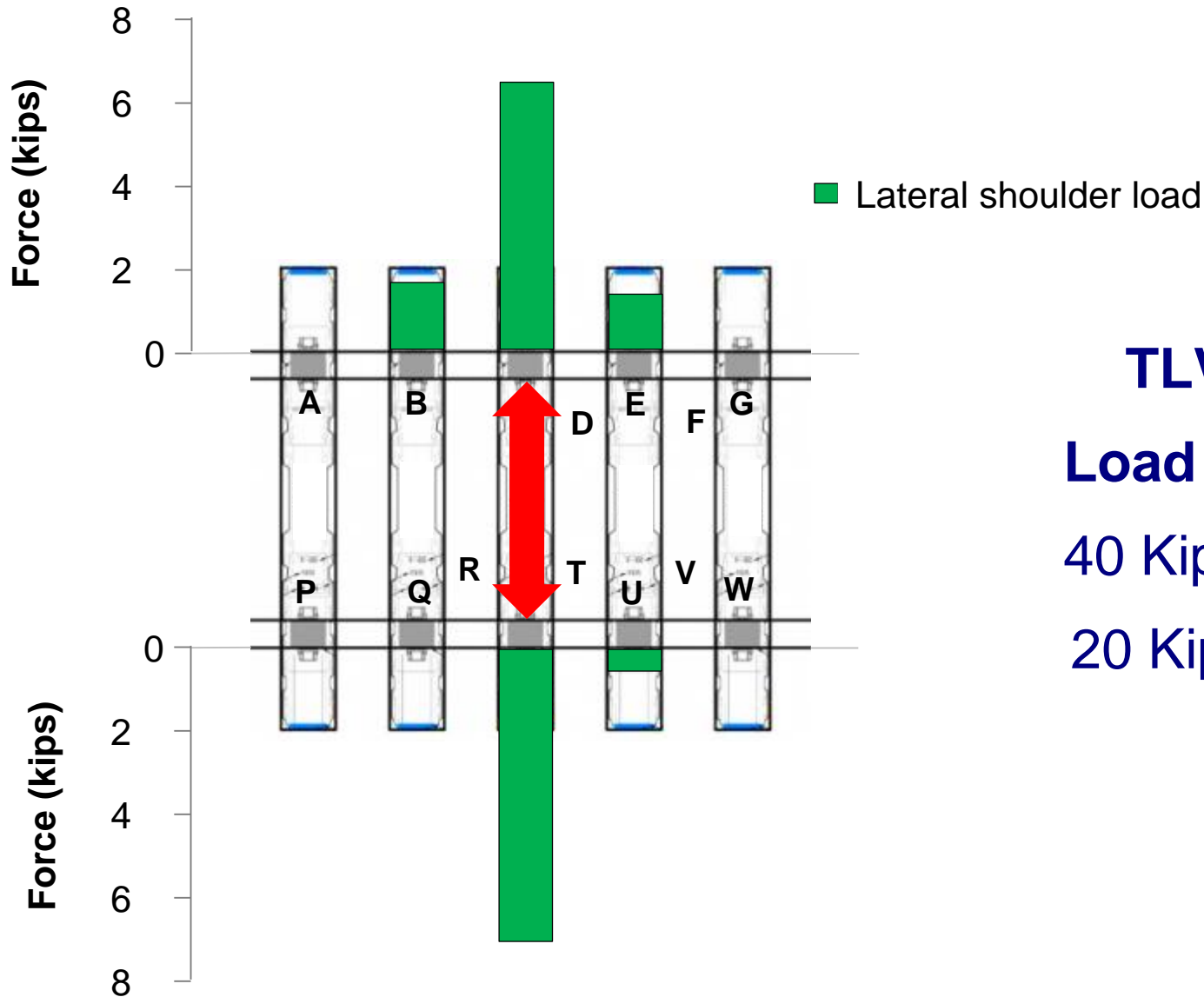

TLV - RTT
Load at Tie CS
 40 Kips Vertical
 20 Kips Lateral

Lateral load distribution-calibrated model

- Based on previous analysis, approximately 50% of the lateral load at a railseat is resisted by the shoulder

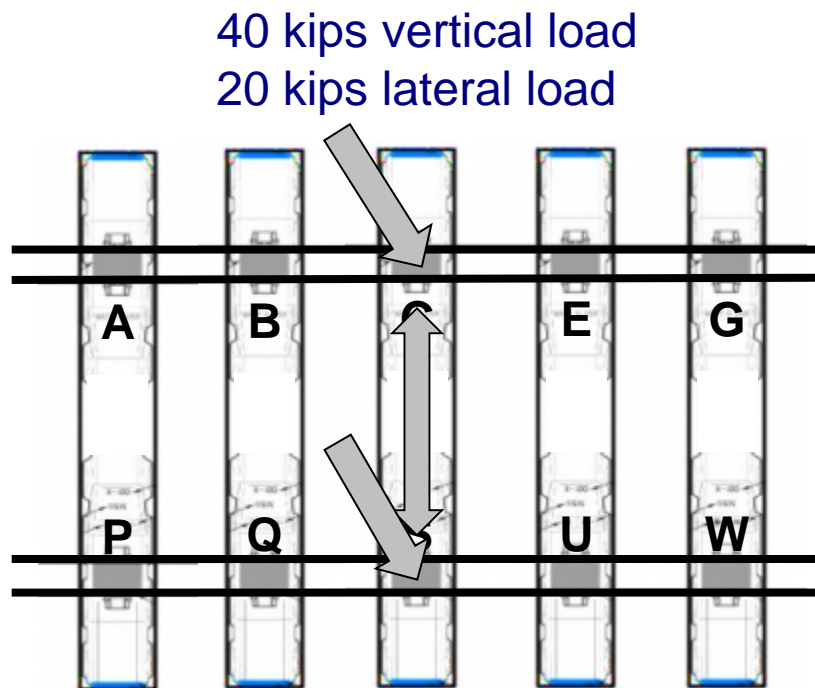

Railseat lateral load – model output (kips)

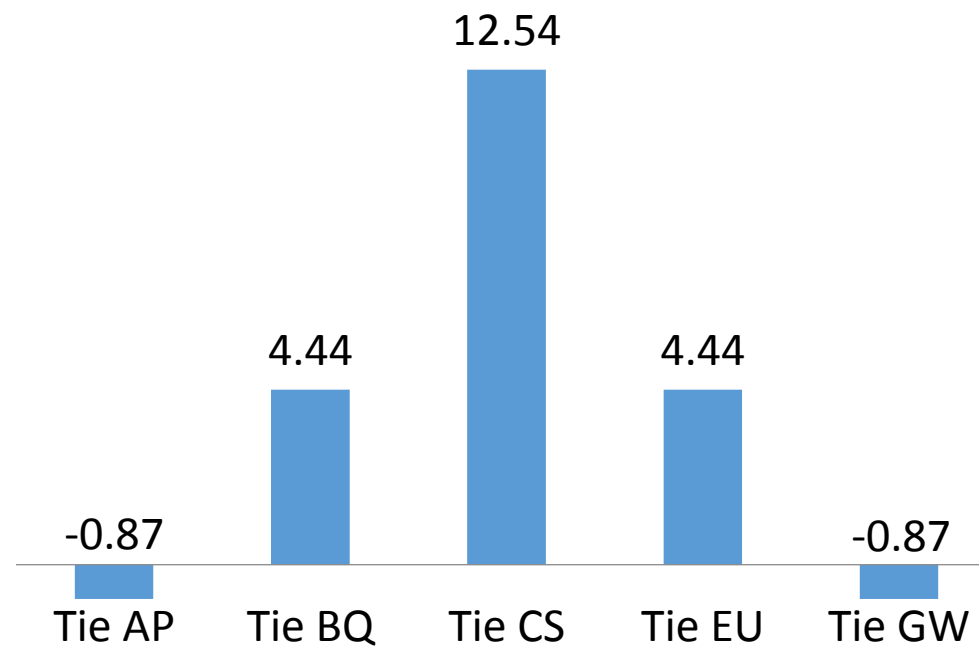

Application of the calibrated model

- Parametric studies have been conducted:
 - Tensile cracking of concrete
 - Lateral load path of the fastening system
 - Bond-slip behavior between prestressing strand and concrete
- Based on design of experiments, results from preliminary parametric studies are used to build a simplified calculation tool (I-TRACK) on track response

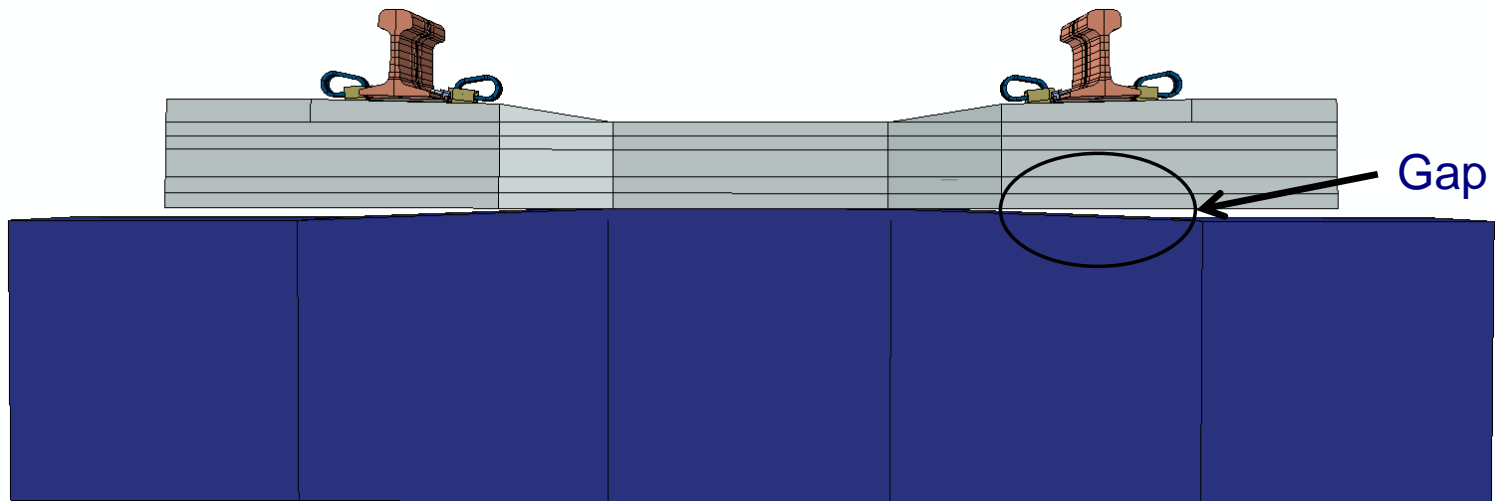

Application of the calibrated model

- I-TRACK outputs track system behavior based on the provided loading scenario and track design
- Based on the output of validated FE model, statistical relationships are derived and embedded in I-TRACK



Conclusions

- Using submodel technique, a global model and a detailed model are used to provide comparison to field experiment
- The models are calibrated with rail and crosstie displacements from the field experiment, and good agreement is observed
- Similar vertical and lateral reaction distribution are observed between the model output and the field test result
- The validated models are used to generate outputs for parametric analyses and a simplified calculation tool (I-TRACK) on track response

Future work

- The submodel technique will be incorporated into the full-scale model to simulate the loading scenario in curved track
- Further parametric studies will be conducted to evaluate:
 - Effect of surface interaction properties (i.e. friction)
 - Vertical track modulus
 - Effect of component geometry on system behavior

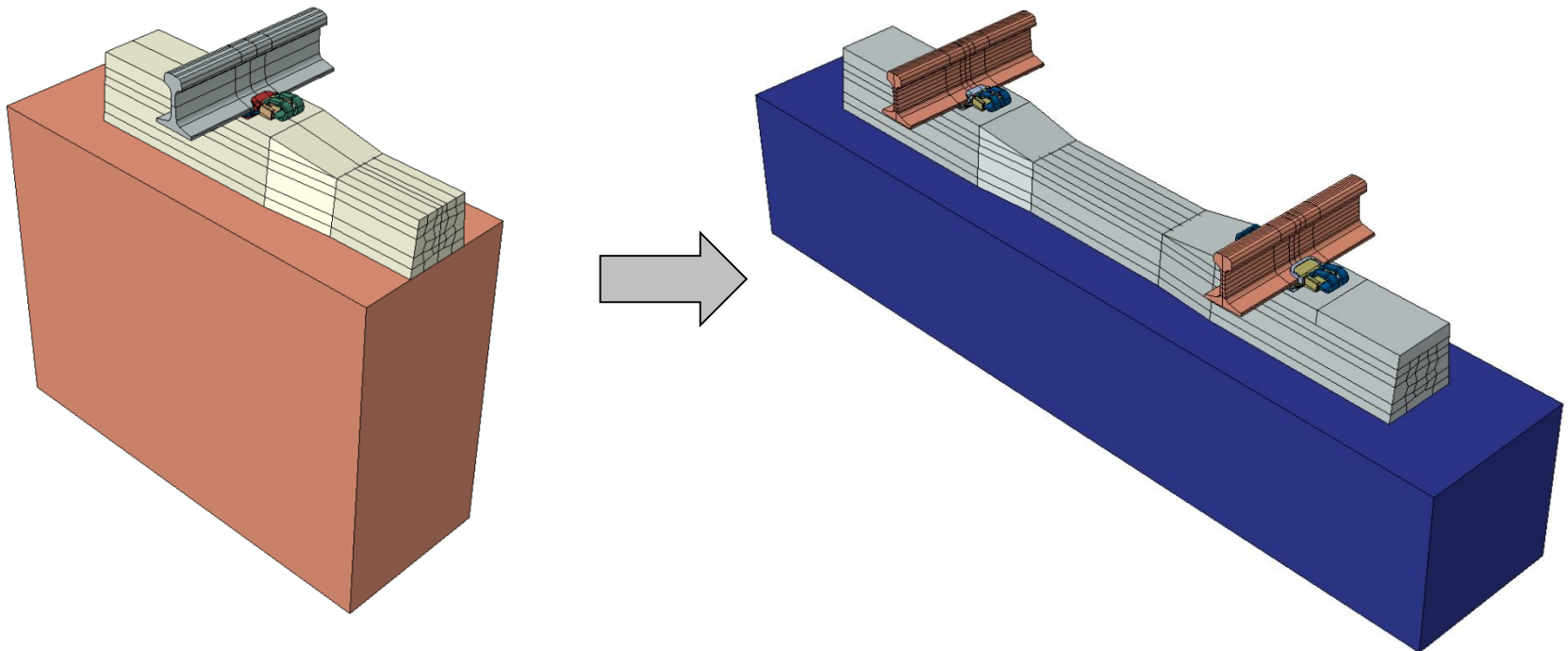



Acknowledgements

U.S. Department of Transportation

Federal Railroad Administration

- Funding for this research has been provided by the Federal Railroad Administration (FRA)
- Industry Partnership and support has been provided by
 - Union Pacific Railroad
 - BNSF Railway
 - National Railway Passenger Corporation (Amtrak)
 - Amsted RPS / Amsted Rail, Inc.
 - GIC Ingeniería y Construcción
 - Hanson Professional Services, Inc.
 - CXT Concrete Ties, Inc., LB Foster Company
 - TTX Company
- Professor Erol Tutumluer for assisting with ballast modeling (UIUC)

FRA Tie and Fastener BAA Industry Partners:



Questions?



(George) Zhe Chen

Department of Civil and Environmental Engineering

University of Illinois at Urbana-Champaign

zhechen3@illinois.edu